

JEDEC STANDARD

Serial Flash Discoverable Parameters (SFDP)

JESD216E

(Revision of JESD216D.01, August 2019)

SEPTEMBER 2021

JEDEC SOLID STATE TECHNOLOGY ASSOCIATION



NOTICE

JEDEC standards and publications contain material that has been prepared, reviewed, and approved through the JEDEC Board of Directors level and subsequently reviewed and approved by the JEDEC legal counsel.

JEDEC standards and publications are designed to serve the public interest through eliminating misunderstandings between manufacturers and purchasers, facilitating interchangeability and improvement of products, and assisting the purchaser in selecting and obtaining with minimum delay the proper product for use by those other than JEDEC members, whether the standard is to be used either domestically or internationally.

JEDEC standards and publications are adopted without regard to whether or not their adoption may involve patents or articles, materials, or processes. By such action JEDEC does not assume any liability to any patent owner, nor does it assume any obligation whatever to parties adopting the JEDEC standards or publications.

The information included in JEDEC standards and publications represents a sound approach to product specification and application, principally from the solid state device manufacturer viewpoint. Within the JEDEC organization there are procedures whereby a JEDEC standard or publication may be further processed and ultimately become an ANSI standard.

No claims to be in conformance with this standard may be made unless all requirements stated in the standard are met.

Inquiries, comments, and suggestions relative to the content of this JEDEC standard or publication should be addressed to JEDEC at the address below, or refer to www.jedec.org under Standards and Documents for alternative contact information.

Published by
©JEDEC Solid State Technology Association 2021
3103 North 10th Street
Suite 240 South
Arlington, VA 22201-2108

JEDEC retains the copyright on this material. By downloading this file the individual agrees not to charge for or resell the resulting material.

PRICE: Contact JEDEC

Printed in the U.S.A.
All rights reserved

PLEASE!

DON'T VIOLATE
THE
LAW!

This document is copyrighted by JEDEC and may not be reproduced without permission.

For information, contact:

JEDEC Solid State Technology Association
3103 North 10th Street
Suite 240 South
Arlington, VA 22201-2107

or refer to www.jedec.org under Standards-Documents/Copyright Information.

SERIAL FLASH DISCOVERABLE PARAMETERS (SFDP) STANDARD**Contents**

	Page
Foreword	viii
Introduction	viii
1 Scope	1
2 Normative reference	1
3 Terms and definitions	2
4 Read SFDP Command Protocol	3
4.1 Instruction	3
4.2 Address	3
4.3 Wait States	4
4.4 Clock Rate	4
4.5 Command Modes	4
4.5.1 Read SFDP (1-1-1) Mode	5
4.5.2 Read SFDP (2-2-2) Mode	6
4.5.3 Read SFDP (4S-4S-4S) Mode	6
4.5.4 Read SFDP (4S-4D-4D) Mode	7
4.5.5 Read SFDP (8D-8D-8D) Mode	7
4.5.6 Fetch SFDP (1-1-1) Mode	8
4.5.7 Fetch SFDP (2-2-2) Mode	8
4.5.8 Fetch SFDP (4S-4S-4S and 4S-4D-4D) Mode	9
4.5.9 Fetch SFDP (8D-8D-8D) Mode	9
5 Read SFDP Behavior	10
5.1 Security	10
5.2 Reset and Hold Functions	10
5.3 Read Wrap	10
5.4 SFDP Address Boundary Wrap	10
5.5 Reserved SFDP Locations	10
6 SFDP Database	11
6.1 SFDP Header Structure	11
6.2 SFDP Header	12
6.2.1 SFDP Header: 1 st DWORD	12
6.2.2 SFDP Header: 2 nd DWORD	13
6.2.3 Definition of SFDP Access Protocol Field	14
6.3 Parameter Headers	19
6.3.1 Parameter Header: 1 st DWORD	19
6.3.2 Parameter Header: 2 nd DWORD	19

6.3.3	Definition of Parameter ID Field.....	20
6.3.4	Example SFDP Headers	22
6.4	JEDEC Basic Flash Parameter Header and Table	25
6.4.1	JEDEC Basic Flash Parameter Header: 1st DWORD	25
6.4.2	JEDEC Basic Flash Parameter Header: 2nd DWORD.....	25
6.4.3	JEDEC Basic Flash Parameter Table Overview.....	26
6.4.4	JEDEC Basic Flash Parameter Table: 1 st DWORD	27
6.4.5	JEDEC Basic Flash Parameter Table: 2 nd DWORD.....	29
6.4.6	JEDEC Basic Flash Parameter Table: 3 rd DWORD.....	29
6.4.7	JEDEC Basic Flash Parameter Table: 4 th DWORD	30
6.4.8	JEDEC Basic Flash Parameter Table: 5 th DWORD	31
6.4.9	JEDEC Basic Flash Parameter Table: 6 th DWORD	31
6.4.10	JEDEC Basic Flash Parameter Table: 7 th DWORD	32
6.4.11	JEDEC Basic Flash Parameter Table: 8 th DWORD	32
6.4.12	JEDEC Basic Flash Parameter Table: 9 th DWORD	33
6.4.13	JEDEC Basic Flash Parameter Table: 10 th DWORD	33
6.4.14	JEDEC Basic Flash Parameter Table: 11 th DWORD	35
6.4.15	JEDEC Basic Flash Parameter Table: 12 th DWORD	37
6.4.16	JEDEC Basic Flash Parameter Table: 13 th DWORD	39
6.4.17	JEDEC Basic Flash Parameter Table: 14 th DWORD	40
6.4.18	JEDEC Basic Flash Parameter Table: 15 th DWORD	41
6.4.19	JEDEC Basic Flash Parameter Table: 16 th DWORD	43
6.4.20	JEDEC Basic Flash Parameter Table: 17 th DWORD	45
6.4.21	JEDEC Basic Flash Parameter Table: 18 th DWORD	46
6.4.22	JEDEC Basic Flash Parameter Table: 19 th DWORD	49
6.4.23	JEDEC Basic Flash Parameter Table: 20 th DWORD	50
6.5	JEDEC Sector Map Parameter Header and Table	53
6.5.1	Sector Map Parameter Header: 1 st DWORD	54
6.5.2	Sector Map Parameter Header: 2 nd DWORD	54
6.5.3	Configuration Detection Command Descriptor, 1 st DWORD	55
6.5.4	Configuration Detection Command Descriptor, 2 nd DWORD	56
6.5.5	Configuration Map Descriptor Header DWORD	57
6.5.6	Region DWORD	57
6.5.7	Sector Map Parameter Table – Example 1	59
6.5.8	Sector Map Parameter Table – Example 2	62
6.6	Replay Protected Monotonic Counters (RPMC) Parameter Header and Table.....	63
6.6.1	Replay Protected Monotonic Counters Parameter Header: 1 st DWORD	63
6.6.2	Replay Protected Monotonic Counters Parameter Header: 2 nd DWORD.....	63
6.6.3	Replay Protected Monotonic Counters Parameter Table, 1 st DWORD	64

6.6.4	Replay Protected Monotonic Counters Parameter Table, 2 nd DWORD	65
6.7	JEDEC 4-byte Address Instruction Parameter Header and Table	65
6.7.1	4-byte Address Instruction Parameter Header: 1 st DWORD	65
6.7.2	4-byte Address Instruction Parameter Header: 2 nd DWORD	66
6.7.3	4-byte Address Instruction Table, 1 st DWORD	67
6.7.4	4-byte Address Instruction Table, 2 nd DWORD	69
6.8	JEDEC eXtended Serial Peripheral Interface (xSPI) Profile 1.0 Parameter Header and Table.....	70
6.8.1	JEDEC xSPI (Profile 1.0) Parameter Header: 1 st DWORD	70
6.8.2	JEDEC xSPI (Profile 1.0) Parameter Header: 2 nd DWORD	70
6.8.3	JEDEC xSPI (Profile 1.0) Parameter Table: 1 st DWORD - Command Codes used in 8D-8D-8D protocol mode.....	71
6.8.4	JEDEC xSPI (Profile 1.0) Parameter Table: 2 nd DWORD - Command Codes used in 8D-8D-8D protocol mode.....	72
6.8.5	JEDEC xSPI (Profile 1.0) Parameter Table: 3 rd DWORD - Memory Commands Supported in 8D-8D-8D protocol mode.....	72
6.8.6	JEDEC xSPI (Profile 1.0) Parameter Table: 4 th DWORD - Dummy cycles used for various frequencies ...	74
6.8.7	JEDEC xSPI (Profile 1.0) Parameter Table: 5 th DWORD - Dummy cycles used for various frequencies ...	74
6.9	JEDEC eXtended Serial Peripheral Interface (xSPI) - Profile 2.0 Parameter Header and Table	75
6.9.1	JEDEC xSPI (Profile 2.0) Parameter Header: 1 st DWORD	75
6.9.2	JEDEC xSPI (Profile 2.0) Parameter Header: 2 nd DWORD	75
6.9.3	JEDEC xSPI (Profile 2.0) Parameter Table: 1 st DWORD - Command Codes used in 8D-8D-8D Profile 2.0 protocol mode.....	76
6.9.4	JEDEC xSPI (Profile 2.0) Parameter Table: 2 nd DWORD - Dummy cycles used for various frequencies ...	77
6.9.5	JEDEC xSPI (Profile 2.0) Parameter Table: 3 rd DWORD - Dummy cycles used for various frequencies ...	78
6.10	Status, Control and Configuration Register Map for SPI Memory Devices	78
6.10.1	SCCR Map for SPI Memory Devices Parameter Header: 1 st DWORD	79
6.10.2	SCCR Map for SPI Memory Devices Parameter Header: 2 nd DWORD	80
6.10.3	SCCR Map for SPI Memory Devices Parameter Table: 1 st DWORD – Volatile registers address offset	80
6.10.4	SCCR Map for SPI Memory Devices Parameter Table: 2 nd DWORD – Non-Volatile registers address offset	80
6.10.5	SCCR Map for SPI Memory Devices Parameter Table: 3 rd DWORD – Generic Addressable Read/Write Status/Control register commands for volatile registers.....	81
6.10.6	SCCR Map for SPI Memory Devices Parameter Table: 4 th DWORD – Generic Addressable Read/Write Status/Control register commands for non-volatile registers	82
6.10.7	SCCR Map for SPI Memory Devices Parameter Table: 5 th DWORD – WIP (Required for xSPI).....	83
6.10.8	SCCR Map for SPI Memory Devices Parameter Table: 6 th DWORD – WEL.....	84
6.10.9	SCCR Map for SPI Memory Devices Parameter Table: 7 th DWORD – Program Error	85
6.10.10	SCCR Map for SPI Memory Devices Parameter Table: 8 th DWORD – Erase Error	86
6.10.11	SCCR Map for SPI Memory Devices Parameter Table: 9 th DWORD – Variable Dummy Cycle Settings – Volatile Register.....	87
6.10.12	SCCR Map for SPI Memory Devices Parameter Table: 10 th DWORD – Variable Dummy Cycle Settings- Non Volatile Register.....	88

6.10.13	SCCR Map for SPI Memory Devices Parameter Table: 11 th DWORD – Variable Dummy Cycle Settings – bit patterns	89
6.10.14	SCCR Map for SPI Memory Devices Parameter Table: 12 th DWORD – Variable Dummy Cycle Settings – bit patterns	90
6.10.15	SCCR Map for SPI Memory Devices Parameter Table: 13 th DWORD – Variable Dummy Cycle Settings – bit patterns	91
6.10.16	SCCR Map for SPI Memory Devices Parameter Table: 14 th DWORD – QPI Mode Enable Volatile	92
6.10.17	SCCR Map for SPI Memory Devices Parameter Table: 15 th DWORD – QPI Mode Enable - Non Volatile	93
6.10.18	SCCR Map for SPI Memory Devices Parameter Table: 16 th DWORD – Octal Mode Enable - Volatile	94
6.10.19	SCCR Map for SPI Memory Devices Parameter Table: 17 th DWORD – Octal Mode Enable- Non-Volatile	95
6.10.20	SCCR Map for SPI Memory Devices Parameter Table: 18 th DWORD – STR or DTR mode select - Volatile	96
6.10.21	SCCR Map for SPI Memory Devices Parameter Table: 19 th DWORD – STR or DTR mode select – Non Volatile	97
6.10.22	SCCR Map for SPI Memory Devices Parameter Table: 20 th DWORD – STR Octal Mode Enable - Volatile	98
6.10.23	SCCR Map for SPI Memory Devices Parameter Table: 21 st DWORD – STR Octal Mode Enable - Non-Volatile	99
6.10.24	SCCR Map for SPI Memory Devices Parameter Table: 22 nd DWORD – DTR Octal Mode Enable - Volatile	100
6.10.25	SCCR Map for SPI Memory Devices Parameter Table: 23 rd DWORD – DTR Octal Mode Enable – Non-Volatile	101
6.10.26	SCCR Map for SPI Memory Devices Parameter Table: 24 th DWORD – DPD Status	102
6.10.27	SCCR Map for SPI Memory Devices Parameter Table: 25 th DWORD – UDPD Status	102
6.10.28	SCCR Map for SPI Memory Devices Parameter Table: 26 th DWORD – Output Driver Strength - Volatile	104
6.10.29	SCCR Map for SPI Memory Devices Parameter Table: 27 th DWORD – Output Driver Strength – Non Volatile	105
6.10.30	SCCR Map for SPI Memory Devices Parameter Table: 28 th DWORD – Output Driver Strength control bit patterns	106
6.11	Status, Control and Configuration Register Map for xSPI Profile 2.0 Memory Devices	107
6.11.1	SCCR Map for xSPI Profile 2.0 Memory Devices Parameter Header: 1 st DWORD	108
6.11.2	SCCR Map for xSPI Profile 2.0 Memory Devices Parameter Header: 2 nd DWORD	108
6.11.3	SCCR Map for xSPI Profile 2.0 Memory Devices Parameter Table: 1 st DWORD – Volatile registers address offset	108
6.11.4	SCCR Map for xSPI Profile 2.0 Memory Devices Parameter Table: 2 nd DWORD – Non-Volatile registers address offset	108
6.11.5	SCCR Map for xSPI Profile 2.0 Memory Devices Parameter Table: 3 rd DWORD – Generic Addressable Read/Write Status/Control register commands	109
6.11.6	SCCR Map for xSPI Profile 2.0 Memory Devices Parameter Table: 4 th DWORD – Program Error	110
6.11.7	SCCR Map for xSPI Profile 2.0 Memory Devices Parameter Table: 5 th DWORD – Erase Error	110
6.11.8	SCCR Map for xSPI Profile 2.0 Memory Devices Parameter Table: 6 th DWORD – Variable Dummy Cycle Settings – Volatile Register	111

6.11.9	SCCR Map for xSPI Profile 2.0 Memory Devices Parameter Table: 7 th DWORD – Variable Dummy Cycle Settings- Non Volatile Register.....	112
6.11.10	SCCR Map for xSPI Profile 2.0 Memory Devices Parameter Table: 8 th DWORD – Variable Dummy Cycle Settings – bit patterns	113
6.11.11	SCCR Map for xSPI Profile 2.0 Memory Devices Parameter Table: 9 th DWORD – Variable Dummy Cycle Settings – bit patterns	114
6.11.12	SCCR Map for xSPI Profile 2.0 Memory Devices Parameter Table: 10 th DWORD – Variable Dummy Cycle Settings – bit patterns	115
6.11.13	SCCR Map for xSPI Profile 2.0 Memory Devices Parameter Table: 11 th DWORD – Output Driver Strength - Volatile.....	116
6.11.14	SCCR Map for xSPI Profile 2.0 Memory Devices Parameter Table: 12 th DWORD – Output Driver Strength – Non Volatile	116
6.11.15	SCCR Map for xSPI Profile 2.0 Memory Devices Parameter Table: 13 th DWORD – Output Driver Strength control bit patterns.....	117
6.12	Status, Control and Configuration Register Map Offsets for Multi-Chip SPI Memory Devices	118
6.12.1	Status, Control and Configuration Register Map Parameter Header: 1 st DWORD	118
6.12.2	Status, Control and Configuration Register Map Parameter Header: 2 nd DWORD	118
6.12.3	Status, Control and Configuration Register Map Parameter Table: 1 st DWORD – Volatile registers address offset for die 1	119
6.12.4	Status, Control and Configuration Register Map Parameter Table: 2 nd DWORD – Non-Volatile registers address offset for die 1	119
6.12.5	Status, Control and Configuration Register Map Parameter Table: 3 rd DWORD – Volatile registers address offset for die 2	119
6.12.6	Status, Control and Configuration Register Map Parameter Table: 4 th DWORD – Non-Volatile registers address offset for die 2	119
6.12.7	Status, Control and Configuration Register Map Parameter Table: 5 th DWORD – Volatile registers address offset for die 3	119
6.12.8	Status, Control and Configuration Register Map Parameter Table: 6 th DWORD – Non-Volatile registers address offset for die 3	119
6.13	Command Sequences to Change to Octal DDR (8D-8D-8D) mode.....	120
6.13.1	Command Sequences to Change to Octal DDR (8D-8D-8D) mode, Parameter Header: 1 st DWORD.....	121
6.13.2	Command Sequences to Change to Octal DDR (8D-8D-8D) mode, Parameter Header: 2 nd DWORD	121
6.13.3	Command Sequences to Change to Octal DDR (8D-8D-8D) mode, Parameter Table: 1 st DWORD - First Command Sequence	121
6.13.4	Command Sequences to Change to Octal DDR (8D-8D-8D) mode, Parameter Table: 2 nd DWORD - First Command Sequence (continued).....	122
6.13.5	Command Sequences to Change to Octal DDR (8D-8D-8D) mode, Parameter Table: 3 rd DWORD - 2 nd Command Sequence	122
6.13.6	Command Sequences to Change to Octal DDR (8D-8D-8D) mode, Parameter Table: 4 th DWORD - 2 nd Command Sequence (continued).....	122
6.13.7	Command Sequences to Change to Octal DDR (8D-8D-8D) mode, Parameter Table: 5 th DWORD - 3 rd Command Sequence	122
6.13.8	Command Sequences to Change to Octal DDR (8D-8D-8D) mode, Parameter Table: 6 th DWORD - 3 rd Command Sequence (continued).....	122

6.13.9	Command Sequences to Change to Octal DDR (8D-8D-8D) mode, Parameter Table: 7 th DWORD - 4 th Command Sequence	123
6.13.10	Command Sequences to Change to Octal DDR (8D-8D-8D) mode, Parameter Table: 8 th DWORD - 4 th Command Sequence (continued).....	123
6.14	x4 Quad IO with DS Parameter Header and Table.....	124
6.14.1	x4 Quad IO with DS Parameter Header: 1st DWORD.....	124
6.14.2	x4 Quad IO with DS Parameter Header: 2nd DWORD	124
6.14.3	x4 Quad IO with DS Parameter Table: 1st DWORD - Command Codes used in 4S-4D-4D protocol mode	124
6.14.4	x4 Quad IO with DS Parameter Table: 2nd DWORD - Command Codes used in 4S-4D-4D protocol mode	126
6.14.5	x4 Quad IO with DS Parameter Table: 3rd DWORD - Memory Commands Supported in 4S-4D-4D protocol mode.....	126
6.14.6	x4 Quad IO with DS Parameter Table: 4th DWORD - Dummy cycles used for various frequencies	126
6.14.7	x4 Quad IO with DS Parameter Table: 5th DWORD - Dummy cycles used for various frequencies	127
6.15	Command Sequences to Change to Quad DDR (4S-4D-4D) mode	128
6.15.1	Command Sequences to Change to Quad DDR (4S-4D-4D) mode, Parameter Header: 1st DWORD	129
6.15.2	Command Sequences to Change to Quad DDR (4S-4D-4D) mode, Parameter Header: 2nd DWORD.....	129
6.15.3	Command Sequences to Change to Quad DDR (4S-4D-4D) mode, Parameter Table: 1st DWORD - First Command Sequence	129
6.15.4	Command Sequences to Change to Quad DDR (4S-4D-4D) mode, Parameter Table: 2nd DWORD - First Command Sequence (continued).....	130
6.15.5	Command Sequences to Change to Quad DDR (4S-4D-4D) mode, Parameter Table: 3rd DWORD - 2nd Command Sequence	130
6.15.6	Command Sequences to Change to Quad DDR (4S-4D-4D) mode, Parameter Table: 4th DWORD - 2nd Command Sequence (continued).....	130
6.15.7	Command Sequences to Change to Quad DDR (4S-4D-4D) mode, Parameter Table: 5th DWORD - 3rd Command Sequence	130
6.15.8	Command Sequences to Change to Quad DDR (4S-4D-4D) mode, Parameter Table: 6th DWORD - 3rd Command Sequence (continued).....	131
6.15.9	Command Sequences to Change to Quad DDR (4S-4D-4D) mode, Parameter Table: 7th DWORD - 4th Command Sequence	131
6.15.10	Command Sequences to Change to Quad DDR (4S-4D-4D) mode, Parameter Table: 8th DWORD - 4th Command Sequence (continued).....	131
6.16	Secure Packet READ/WRITE Parameter Header and Table.....	132
6.16.1	Secure Packet READ/WRITE Parameter Header: 1 st DWORD.....	132
6.16.2	Secure Packet READ/WRITE Parameter Header: 2 nd DWORD.....	132
6.16.3	Secure Packet READ/WRITE Parameter Table, 1 st DWORD	133
6.16.4	Secure Packet READ/WRITE Parameter Table, 2 nd DWORD	133
6.16.5	Secure Packet READ/WRITE Parameter Table, 3 rd DWORD.....	133
6.16.6	Secure Packet READ/WRITE Parameter Table, 4 th DWORD.....	134
7	Rules for Header and Table Additions and Modifications	135
8	Legacy Compatibility	136

Annex A (Informative) Procedure For Requesting Function Specific ID.....	137
Annex B (informative) Differences between revisions.....	138
B.1 Differences between JESD216E and JESD216D.....	138
B.2 Differences between JESD216D and JESD216C.....	138
B.3 Differences between JESD216C and JESD216B.....	140
B.2 Differences between JESD216B and JESD216A.....	142
B.1 Differences between JESD216A and JESD216.....	142
Standard Improvement Form.....	End
Figure 1 — Read SFDP (1-1-1) Mode Timing Diagram.....	5
Figure 2 — Read SFDP (2-2-2) Mode Timing Diagram.....	6
Figure 3 — Read SFDP (4S-4S-4S) Mode Timing Diagram.....	6
Figure 4 — Read SFDP (4S-4D-4D) Mode Timing Diagram.....	7
Figure 5 — Read SFDP (8D-8D-8D) Mode Timing Diagram.....	7
Figure 6 — Fetch SFDP (1-1-1) Mode Timing Diagram.....	8
Figure 7 — Fetch SFDP (2-2-2) Mode Timing Diagram.....	8
Figure 8 — Fetch SFDP (4S-4S-4S and 4S-4D-4D) Mode Timing Diagram.....	9
Figure 9 — Fetch SFDP (8D-8D-8D) Mode Timing Diagram.....	9
Figure 10 — Overall Header Structure.....	11
Figure 11 — xSPI NAND Class-1 Device Read SFDP Flow.....	17
Figure 12 — xSPI NAND Class-2 Device Read SFDP Flow.....	18
Figure 13 — Example SFDP Header with single Basic Parameter Table.....	23
Figure 14 — Example SFDP Header with single Basic Parameter Table Word based (xSPI Profile 2.0).....	23
Figure 15 — Example SFDP Header with two Basic parameter Tables.....	23
Figure 16 — Example SFDP Header with two basic Parameter Tables and one optional (4-Byte Address) Function Specific Tables.....	24
Figure 17 — Example SFDP Header with two basic Parameter Tables and two optional (4-Byte Address and Status, Control and Configuration Register Map) Function Specific Tables.....	24
Figure 18 — Data Strobe Waveforms in STR Mode – Option 11b.....	47
Figure 19 — Data Strobe Waveforms in STR Mode - Option 10b.....	47
Figure 20 — Data Strobe Waveforms in STR Mode - Option 01b.....	48

Foreword

This standard was prepared by the JEDEC SFDP Task Group authorized by the JC-42.4 Committee Chairman.

The intended audience is serial flash vendors and engineers writing device drivers for SFDP compliant serial flash devices.

The participating SFDP TG members included volunteers from Adesto, Infineon, Giga Device, Intel, ISSI, Macronix, Micron, Microchip, NXP, Sanyo, and Winbond.

Introduction

The Serial Flash Discoverable Parameter (SFDP) standard provides a consistent method of describing the functional and feature capabilities of serial flash devices in a standard set of internal parameter tables. These parameter tables can be interrogated by host system software to enable adjustments needed to accommodate divergent features from multiple vendors.

The SFDP standard defines a common parameter table describing important device characteristics and serial access methods used to read the parameter table data. Optional Special Function parameter tables for erase sector address map and 4-byte address instructions are included. In the JESD216D revision are optional Special Function parameter tables for the JEDEC x4 (Quad) eXpanded Serial Peripheral Interface (x4 xSPI). New in the JESD216E revision is a description of the Replay Protected Monotonic Counter (RPMC) functionality and also descriptions of the Secure Read and Secure Write packet transfer transactions. Additional parameter headers and tables can be specified by future revisions of this standard or by flash vendors and are optional.

SERIAL FLASH DISCOVERABLE PARAMETERS (SFDP) STANDARD

(From JEDEC Board Ballot JCB-21-20, formulated under the cognizance of the JC-42.4 Committee on Nonvolatile Memory.)

1 Scope

The SFDP standard defines the structure of the SFDP database within the memory device and methods used to read its data.

The JEDEC-defined header with Parameter ID FF00h and the related Basic Parameter Table is mandatory. This header and table provide basic information for a Serial Peripheral Interface (SPI) protocol memory. Additional headers and tables are optional.

The read command protocol using various I/O modes and standard clock rate are specified. The device electrical parameters are not specified.

2 Normative reference

The following normative documents contain provisions that, through reference in this text, constitute provisions of this standard. For dated references, subsequent amendments to, or revisions of, any of these publications do not apply. However, parties to agreements based on this standard are encouraged to investigate the possibility of applying the most recent editions of the normative documents listed. For undated references, the latest edition of the normative document referred to applies.

1. JEP106, *Standard Manufacturers Identification Code* (see www.jedec.org for latest revision)
2. NIST SP800-147, *BIOS Protection Guidelines* (<http://nvlpubs.nist.gov/nistpubs/Legacy/SP/nistspecialpublication800-147.pdf>)
3. JEDEC Standard JESD251, *eXpanded Serial Peripheral Interface (xSPI) for Non Volatile Memory Devices*
4. JEDEC Standard JESD252, *Serial Flash Reset Signaling Protocol*
5. JEDEC Standard JESD230C, *NAND Flash Interface Interoperability*

3 Terms and definitions

For the purposes of this standard, the following terms and definitions apply.

00b: The ‘b’ suffix indicates the ‘00’ digits are a binary representation of the number.

00h: The ‘h’ suffix indicates the ‘00’ digits are a hexadecimal representation of the number.

address: The three or four byte value following some instructions that is used to select a location within an address space of the flash memory.

basic parameter table: The table pointed to by Parameter ID FF00h. Contains general information about the flash device's capabilities.

block: A group of contiguous sectors.

command: The combination of the instruction, address, optional mode bits, wait states, and data cycles used to initiate functions or transfer information between the controller and the serial flash.

controller: The serial bus initiator.

Double Transfer Rate (DTR): Instruction, address, and/or data may be input or output on both the rising and falling edges of the clock. Note: The term “Double Data Rate” (DDR) may also be encountered in some documentation.

Data Strobe (DS): Target to initiator strobe signal used to capture data sent by the target.

dummy cycles: Clock cycles during which no data is transferred to or from a memory.

DWORD: Four consecutive 8-bit bytes used as the basic 32-bit building block for headers and parameter tables.

instruction: The one byte code used to initiate a function in the serial flash or identify the type of information transfer between the controller and the serial flash.

mode bits: Optional control bits that follow the address bits. These bits are driven by the controller if they are specified.

wait states: Required clock cycles between the address bits or optional mode bits and the start of data when reading from the flash device. Some device data sheets describe these as dummy cycles because no information is transferred between the controller and memory during these cycles. Neither controller nor memory are required to drive the data lines during these cycles.

read latency: On flash read instructions, the total number of clocks between end of address and the start of data. The sum of clocks for mode bits and clocks for wait states equals the Read Latency.

sector: The minimum granularity - size and alignment - of an area that can be erased in the data array of a flash memory device. Different areas within the address range of the data array may have a different minimum erase granularity (sector size).

3 Terms and definitions (cont'd)

(x-y-z): Command mode nomenclature used in JESD216A and JESD216B to indicate the number of active pins used for the instruction (x), address (y), and data (z). For new entries in the current standard, this is replaced by the (An-Bn-Cn) nomenclature described below. The (x-y-z) nomenclature is equivalent to (AS-BS-CS) unless otherwise noted. (4-4-4) is therefore equivalent to (4S-4S-4S).

(An-Bn-Cn): Command mode nomenclature used to indicate the number of active pins used for the instruction (A), address (B), and data (C), and the data rate used for each. Data rates(n) can be single (S) and dual (D). At the present time, the only valid Read SFDP command modes are: (1S-1S-1S), (2S-2S-2S), (4S-4S-4S), (4S-4D-4D), and (8D-8D-8D). (4S-4D-4D), and (8D-8D-8D) modes also use a Data Strobe (DS) as part of the communication protocol.

4 Read SFDP Command Protocol

4.1 Instruction

The Read SFDP instruction code is 5Ah.

- The very first SFDP instruction a Device receives from a Host is the READ SFDP (5Ah) instruction during POR discovery phase.

The Fetch SFDP instruction code is 5Bh.

- This instruction is added to support Long Latency NVM Devices. This instruction tells a Device to load all parameter tables, defined in SFDP Header Structure, from device Memory Cell Array to Device Cache Buffer. NAND Flash device is the first Long Latency NVM device supported by SFDP. Host shall wait for 120 μ s tR (Read Latency) then Host can re-issue Read SFDP (5Ah) instruction to access SFDP parameter table and Long Latency NVM device MSPT (Media Specific Parameter Table) table.
- Fetch SFDP (5Bh) instruction shall follow the same mode established between a Host and a Device during POR Read SFDP (5Ah) instruction phase.

NOTE Fetch SFDP instruction is only applicable for POR device discovery process for now. If needed, additional details of normal connected operation description would be available after JEDEC SPI NAND document is available.

4.2 Address

Indicates the starting byte address in the SFDP area and is always expressed as a three byte field for (1S-1S-1S), (2S-2S-2S), (4S-4S-4S), and (4S-4D-4D) modes. For the (8D-8D-8D) mode, 3 or 4 byte addressing may be used.

- Fetch SFDP (5Bh) instruction does not have or require an address field.

4.3 Wait States

Following the address, eight clocks are required before valid data is clocked out for (1S-1S-1S), (2S-2S-2S), (4S-4S-4S), and (4S-4D-4D) modes. For the (8D-8D-8D) mode, a variable number of wait states (dummy cycles) may be used.

- Not applicable for Fetch SFDP (5Bh) instruction since it does not have an address field and does not output data.

4.4 Clock Rate

SFDP compliant devices must support 50 MHz operation for the Read SFDP command (instruction 5Ah). Devices may support a wider frequency range, but a controller can always run SFDP cycles at 50 MHz or less and get valid results.

- Fetch SFDP (5Bh) instruction shall follow the same mode established between a Host and a Device during Read SFDP (5Ah) instruction phase.

4.5 Command Modes

The Read SFDP command can be used with device supported modes of (1-1-1), (2-2-2), (4-4-4), or (4S-4D-4D), but the instruction (5Ah), address (24 bits), eight wait states, and 50 MHz requirements remain the same. For the (8D-8D-8D) mode, the instruction (5Ah) and 50 MHz requirements remain the same, while 24 or 32 address bits, and a variable number of wait states (dummy cycles) may be used. Support for SFDP does not imply or require that the target device supports 2-2-2, 4-4-4 or 8-8-8 mode. If the controller knows a priori the mode in which the flash device is configured, then it can issue the Read SFDP command in that mode. If the controller does not know, then a suggested algorithm is to try to read the SFDP signature (see 6.1) in 4-4-4 mode, if that fails try 2-2-2 mode, and if that fails try 1-1-1 mode. For Octal devices, these typically support SFDP read operation in both 1S-1S-1S mode and 8D-8D-8D mode. If the host controller does not know exactly which protocol mode is used for SFDP in 8D-8D-8D mode, this information can be found by reading SFDP in 1S-1S-1S mode first. (To read an unknown device directly in 8D-8D-8D mode, the host controller may read from address 0, and count the number of dummy clocks required before the SFDP signature is received.)

- Fetch SFDP (5Bh) instruction shall follow the same mode established between a Host and a Device during Read SFDP (5Ah) instruction phase.

4.5 Command Modes (cont'd)

Timing Diagram Signal Definitions:

- CS# = Select, low active. Memory device selection signal also often referred to as Chip Select or Chip Enable
- CK = Clock. Serial clock to the memory also often referred to as SCLK.
- IO0 = Data input or output zero. The least significant memory data input or output also often referred to as DQ0 or Serial Input (SI) when not used for two, four or eight bit data I/O.
- IO1 = Data input or output one. The next most significant memory data input or output above IO0, also often referred to as DQ1 or Serial Output (SO) when not used for two, four or eight bit data I/O.
- IO2 = Data input or output two. The next most significant memory data input or output above IO1, also often referred to as DQ2 or Write Protect, low active (WP#) when not used for four or eight bit data I/O.
- IO3 = Data input or output three. The most significant memory data input or output, also often referred to as DQ3 or Hold, low active (HOLD#) when not used for four or eight bit data I/O.
- IO4-7 = Data input or output four to seven. Used for eight bit data I/O (8D-8D-8D). Also often referred to as DQ4-7.
- DS = Data Strobe. Used for (4S-4D-4D) and (8D-8D-8D). The Data Strobe (DS) signal provides a timing reference for information transfer on the IO signals from the target to the initiator. DS is an output signal from the xSPI target device that is aligned with the edges of output data and is used by the host interface to optimize high frequency read data capture. DS may optionally be used as a signal from the target to the initiator, to indicate the duration of initial access latency or, as a signal from the initiator to the target, to indicate write data masking.

4.5.1 Read SFDP (1-1-1) Mode

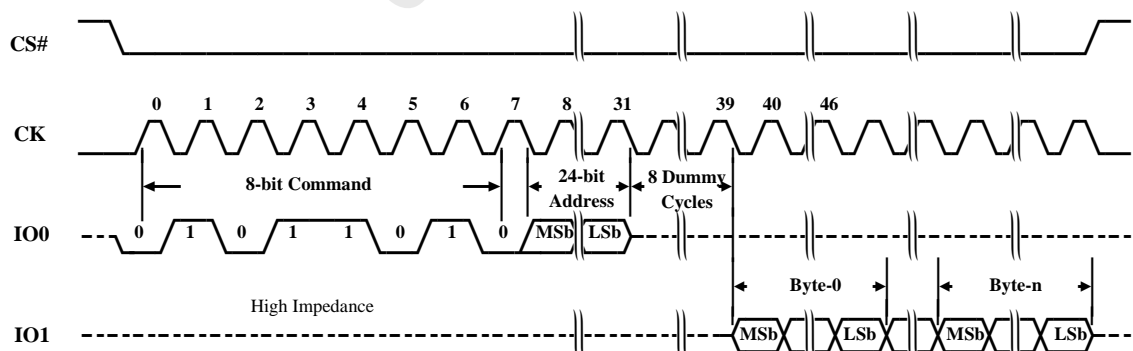

Figure 1 — Read SFDP (1-1-1) Mode Timing Diagram

4.5.2 Read SFDP (2-2-2) Mode

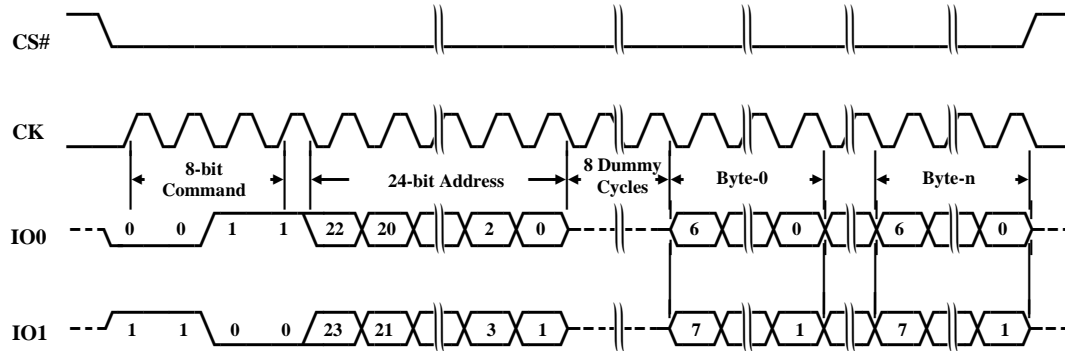

Figure 2 — Read SFDP (2-2-2) Mode Timing Diagram

4.5.3 Read SFDP (4S-4S-4S) Mode

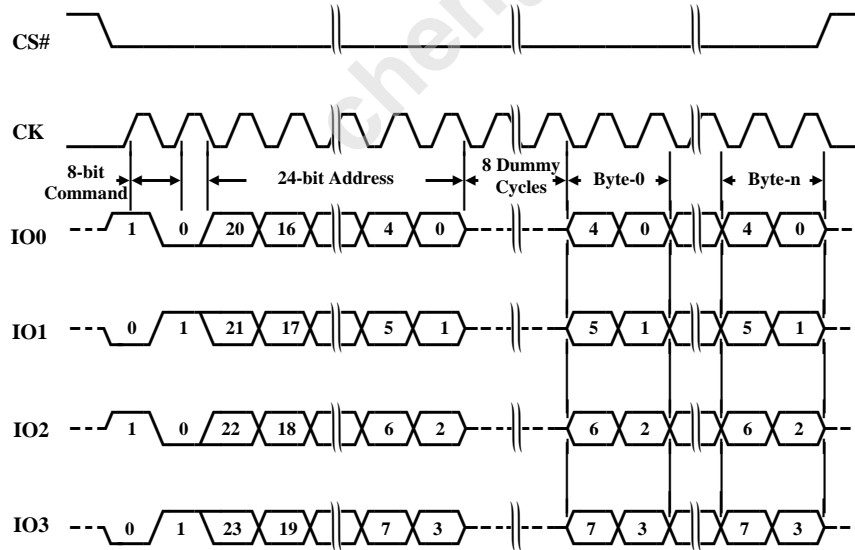
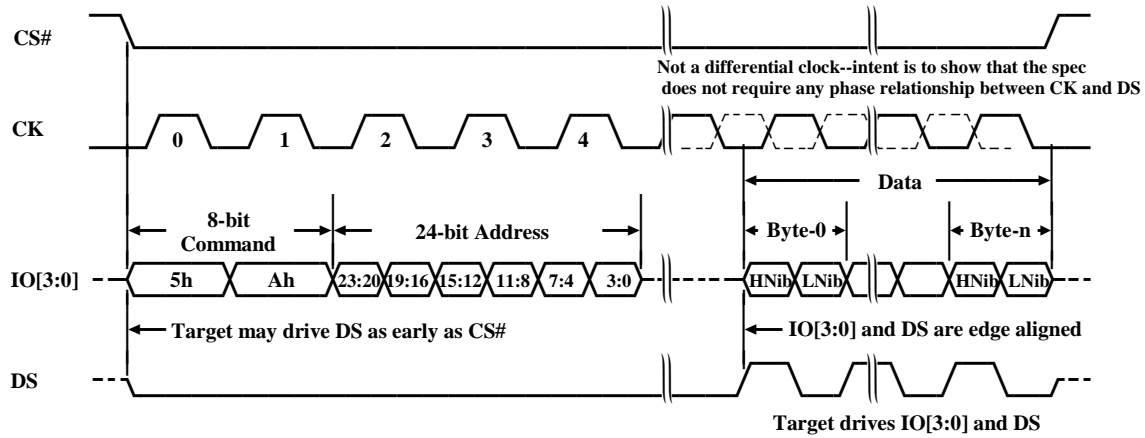

Figure 3 — Read SFDP (4S-4S-4S) Mode Timing Diagram

4.5.4 Read SFDP (4S-4D-4D) Mode



NOTE DS is optional in this mode.

Figure 4 — Read SFDP (4S-4D-4D) Mode Timing Diagram

4.5.5 Read SFDP (8D-8D-8D) Mode

See 6.4.21 for details about the addressing options in this mode.

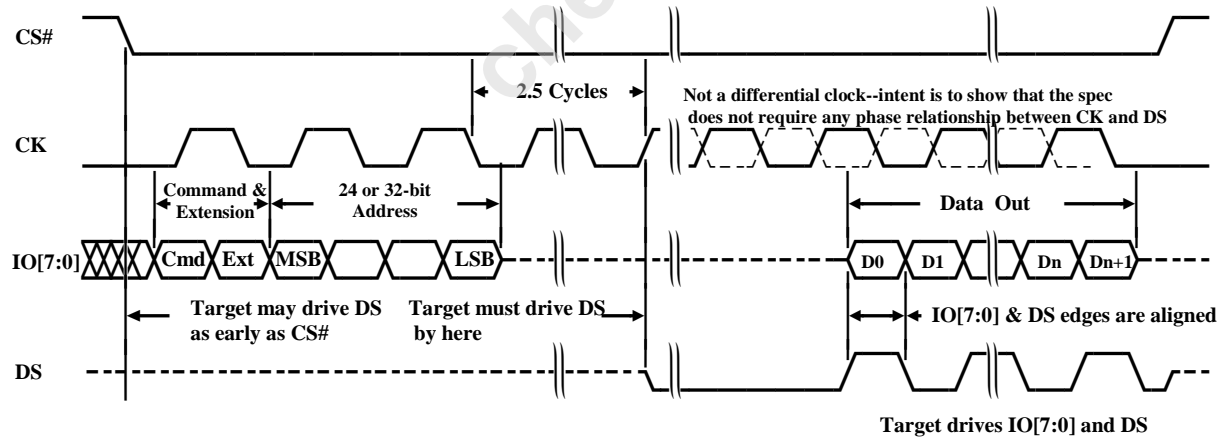

Figure 5 — Read SFDP (8D-8D-8D) Mode Timing Diagram

4.5.6 Fetch SFDP (1-1-1) Mode

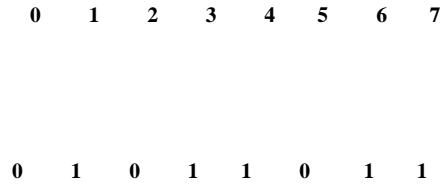

Figure 6 — Fetch SFDP (1-1-1) Mode Timing Diagram

4.5.7 Fetch SFDP (2-2-2) Mode

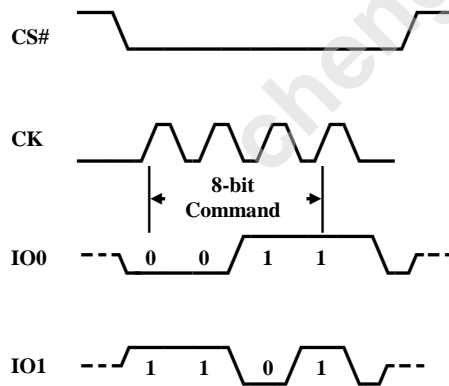

Figure 7 — Fetch SFDP (2-2-2) Mode Timing Diagram

4.5.8 Fetch SFDP (4S-4S-4S and 4S-4D-4D) Mode

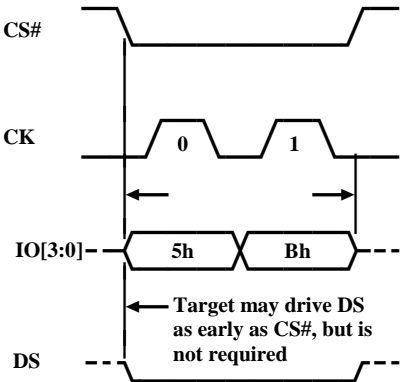

Figure 8 — Fetch SFDP (4S-4S-4S and 4S-4D-4D) Mode Timing Diagram

4.5.9 Fetch SFDP (8D-8D-8D) Mode

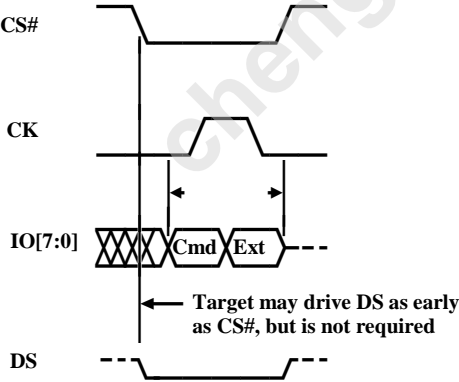

Figure 9 — Fetch SFDP (8D-8D-8D) Mode Timing Diagram

5 Read SFDP Behavior

5.1 Security

The SFDP and flash memory address ranges must never overlap. This ensures that address range checking the controller may perform to prevent access to security keys or other sensitive information stored in flash cannot be bypassed. Also, for PC BIOS applications non-overlap is required to comply with NIST SP800-147.

Addresses beyond the end of the SFDP tables must not alias into the flash memory. Regardless of the implementation, writes to SFDP tables must be permanently disabled before the memory device is released to a customer by the memory vendor factory.

5.2 Reset and Hold Functions

Reset and Hold functionality will be available during the Read SFDP command if the memory device command mode supports these features. Note that these functions may not be available in all modes, as the pins used for Reset or Hold may be reused for I/O pins in Quad and Octal modes.

The JEDEC SPI Protocol Reset is an alternative Reset function that may be used in any mode for devices which support it. See the JEDEC SPI Protocol Reset spec for details.

5.3 Read Wrap

Not supported with the Read SFDP command--even when a memory device defaults to Read Wrap-around mode for other read commands. Only continuous (sequential) read is supported with the Read SFDP command.

5.4 SFDP Address Boundary Wrap

Device behavior when the Read SFDP command crosses the SFDP structure boundary is not defined except for the security restriction specified in 5.1. There is no requirement for the address counter to wrap back to the beginning of the structure and the data read after that point is not specified.

5.5 Reserved SFDP Locations

The content of reserved SFDP locations (memory within the SFDP address space that has not yet been defined or used) is not specified, but recommended to be all FFh.

6 SFDP Database

6.1 SFDP Header Structure

The format of the SFDP header is shown in Figure 10 — Overall Header Structure.

	[31:24]	[23:16]	[15:8]	[7:0]	Hex byte location
SFDP Header	Serial Flash Discoverable Parameters (SFDP) Signature = 50444653h Byte 3 = "P" Byte 2 = "D" Byte 1 = "F" Byte 0 = "S"				[3h:0h]
	SFDP Access Protocol	Number of Parameter Headers (NPH)	SFDP Major Revision	SFDP Minor Revision	[7h:4h]
1st Parameter Header	Parameter Length (in double words)	Parameter Major Revision	Parameter Minor Revision	Parameter ID LSB JEDEC ID (00h)	[Bh:8h]
	Parameter ID MSB JEDEC ID (FFh)	Parameter Table Pointer (byte address)			[Fh:Ch]
2nd Parameter Header (optional)	Parameter Length (in double words)	Parameter Major Revision	Parameter Minor Revision	Parameter ID LSB	[13h:10h]
	Parameter ID MSB	Parameter Table Pointer (byte address)			[17h:14h]
...					
Nth Parameter Header (optional)	Parameter Length (in double words)	Parameter Major Revision	Parameter Minor Revision	Parameter ID LSB	
	Parameter ID MSB	Parameter Table Pointer (byte address)			

Figure 10 — Overall Header Structure

6.2 SFDP Header

The SFDP Header is located at address 000000h of the SFDP data structure. It identifies the SFDP Signature, the number of parameter headers, and the SFDP revision numbers.

Both the SFDP header and the individual parameter table headers include Major and Minor revision numbers.

Major revisions require code (BIOS/firmware) or hardware change to get previously defined discoverable parameters. For example, changes that reorganize previously defined fields.

Minor revisions are changes that define previously reserved fields, add fields to the end, or that clarify definitions of existing fields.

JESD216B maintains backwards compatibility with JESD216A, defines previously reserved bits in the 15th DWORD of the Basic Flash Parameter Table and adds optional Function Specific table definitions.

JESD216C maintains backwards compatibility with JESD216B, defines previously reserved bits in the 2nd DWORD of the SFDP Header and adds optional Function Specific table definitions.

JESD216D maintains backwards compatibility with JESD216C.

JESD216E maintains backwards compatibility with JESD216D, defines Secure Read and Secure Write transaction details as well as Replay Protected Monotonic Counter (RPMC) functionality.

The revision numbers of vendor-defined and Function Specific tables follow the same guidelines as the Basic Parameter Table.

Major vs. Minor Revisions

Major revisions indicate that the table structure has changed and may not be backwards compatible with software written for an earlier revision of SFDP.

Increments of minor revisions indicate that fields or DWORDS have been added but the definition of existing fields is unchanged. Software should accept any minor revision number and read only the number of parameter table fields that the software requires. Users should accept any minor revision greater than or equal to the current revision. All fields defined in the current tables will be unchanged in subsequent minor revisions. Undefined or reserved fields may be updated.

6.2.1 SFDP Header: 1st DWORD

Bits	Description
31:0	SFDP Signature Allows a user to know that the information is valid. Signature[31:0]: 50444653h

6.2.2 SFDP Header: 2nd DWORD

Bits	Description
31:24	SFDP Access Protocol See 6.2.3
23:16	Number of Parameter Headers (NPH) Specifies the number of parameter headers in the SFDP data structure. This number is 0-based. Therefore, 0 indicates 1 parameter header. The value of this field is not defined by this standard. It is dependent on the number of tables a vendor implements. The value FFh is reserved for future extensions of this standard.
15:8	SFDP Major Revision Number This 8-bit field indicates the major revision number of this standard. The value in this field is 01h for devices which implement the JESD216E revision (unchanged from JESD216D revision). NOTE The value of this field may only be changed by an update to the JESD216 standard.
7:0	SFDP Minor Revision Number This 8-bit field indicates the minor revision number of this standard. The value in this field is 09h for devices which implement the JESD216E revision. NOTE The value of this field may only be changed by an update to the JESD216 standard.

6.2.3 Definition of SFDP Access Protocol Field

The purpose of the Access Protocol Field is to provide the host controller necessary information about how to read the SFDP command. In early versions of this spec (up to and including JESD216B) this field was FFh. The value FFh still indicates that the SFDP command structure is backwards compatible with the description given in JESD216B. The device will in this case respond to one or more of the SFDP command options as described in JESD216B. Any other value indicates that the SFDP command will behave differently in one or more aspects.

(8D-8D-8D) devices still use FFh as the parameter value if they boot up in one of the modes that are compatible with the JESD216B revision. (Typically this would be (1S-1S-1S) mode.)

For devices where the boot mode may be changed by the user by setting fuses or similar, the device has to update the value returned in the SFDP Access Protocol Field according to the fuse settings.

SFDP Command Parameter Value		
Decimal	Hex	
0-239	00h-EFh	Reserved for future use
240	F0h	<p>xSPI NAND class-1 device – parameter data is available in device cache buffer.</p> <p>xSPI Octal, (8D, 8D, 8D) operation, 4-byte addressing for SFDP command, 8 wait states.</p> <p>NAND Flash devices use JESD230C Parameter Page as MSPT.</p> <p>Follow Long latency NVM Class-1 device SFDP access behavior for reading SFDP & MSPT data (see Figure 11):</p> <p>SFDP Parameter Table & NVM Media Specific Parameter Table are available in Device's Cache Buffer before Device is ready to process Host commands during POR process,</p> <ol style="list-style-type: none"> After POR, Host always first issue READ SFDP (5Ah) with start address '00h' for device discovery <ul style="list-style-type: none"> Device returns the SFDP Header with the appropriate parameter value code representing NVM Class-1 Device after received READ SFDP (5Ah) command with start address '00h' Host issues 2nd (and more if needed) READ SFDP (5Ah) command(s) with a non-zero start address to access SFDP and MSPT table contents <p>Device returns the SFDP/MSPT table data beginning from the start address specified in READ SFDP (5Ah) command.</p>

6.2.3 Definition of SFDP Access Protocol Field (cont'd)

SFDP Command Parameter Value		
Decimal	Hex	
241	F1h	<p>xSPI NAND class-2 device – parameter data is not available in device cache buffer.</p> <p>xSPI Octal, (8D, 8D, 8D) operation, 4-byte addressing for SFDP command, 8 wait states.</p> <p>NAND Flash devices use JESD230C Parameter Page as MSPT.</p> <p>Follow Long latency NVM Class-2 device SFDP access behavior for reading SFDP & MSPT data (see Figure 12):</p> <p>Parameter Tables are not available in the device's Cache Buffer before Device is ready to process Host commands during POR process,</p> <ol style="list-style-type: none"> After POR, Host always first issue READ SFDP (5Ah) with start address '00h' for device discovery <ul style="list-style-type: none"> Device returns SFDP Header with the appropriate parameter value code representing NVM Class-2 Device after received READ SFDP (5Ah) command with '00h' start address Host issue FETCH SFDP (5Bh) command to Device Host: wait 120µs; Device: fetches SFDP & MSPT tables from memory cell array to Device's Cache Buffer Host issues 2nd (and more if needed) READ SFDP (5Ah) command(s) with a non-zero start address to access SFDP and MSPT table contents <ul style="list-style-type: none"> Device returns the SFDP/MSPT Table data beginning from the start address specified in READ SFDP (5Ah) command
242	F2h	<p>Reserved for xSPI NAND class-3 device, Combo device includes both NOR Flash & Class-1 Long Latency NVM.</p> <p>-for octal interface to low Latency combo with SFDP table in the cache and can use a 5Ah command</p>
243	F3h	<p>Reserved for xSPI NAND class-3 device – combo device with both NOR Flash device and Class-2 Long Latency NVM device</p> <p>-for octal interface to low Latency combo with SFDP table is not in the cache and requires a 5Bh command before the 5Ah command</p>
244	F4h	<p>SPI NAND class-1 device – parameter data is available in device cache buffer Legacy option: Behavior consistent with JESD216B revision.</p> <p>(1S-1S-1S), (2S-2S-2S) or (4S-4S-4S) operation, 3-byte addressing for SFDP command, 8 wait states.</p> <p>NAND Flash devices use JESD230C Parameter Page as MSPT</p> <p>Follow Long latency NVM Class-1 device SFDP access behavior for reading SFDP & MSPT data (see Figure 11)</p> <p>Figure 11)</p>

6.2.3 Definition of SFDP Access Protocol Field (cont'd)

SFDP Command Parameter Value		
Decimal	Hex	
245	F5h	SPI NAND class-2 device – parameter data is not available in device cache buffer Legacy option: Behavior consistent with JESD216B revision. (1S-1S-1S), (2S-2S-2S) or (4S-4S-4S) operation, 3-byte addressing for SFDP command, 8 wait states. NAND Flash devices use JESD230C Parameter Page as MSPT Follow Long latency NVM Class-2 device SFDP access behavior for reading SFDP & MSPT data
246	F6h	Reserved for SPI NAND class-3 device, Combo device includes both NOR Flash & Class-1 Long Latency NVM.
247	F7h	Reserved for SPI NAND class-3 device, Combo device includes both NOR Flash & SPI Class-2 Long Latency NVM.
248:249	F8h:F9h	Reserved for future use
250	FAh	xSPI NOR Profile 2 (8D, 8D, 8D) operation, 5-byte addressing, SFDP command (WREN1 & WREN2), Configurable wait states.
251	FBh	Reserved for future use
252	FCh	xSPI NOR Profile 1 Octal, (8D, 8D, 8D) operation, 3-byte addressing + 1/2 Cycle for Octal DTR Alignment for SFDP command, 8 wait states.
253	FDh	xSPI NOR Profile 1 Octal, (8D, 8D, 8D) operation, 4-byte addressing for SFDP command, 20 wait states.
254	FEh	xSPI NOR Profile 1 Octal, (8D, 8D, 8D) operation, 4-byte addressing for SFDP command, 8 wait states.
255	FFh	Legacy option: Behavior consistent with JESD216B revision. (1S-1S-1S), (2S-2S-2S) or (4S-4S-4S) operation, 3-byte addressing for SFDP command, 8 wait states.

6.2.3 Definition of SFDP Access Protocol Field (cont'd)

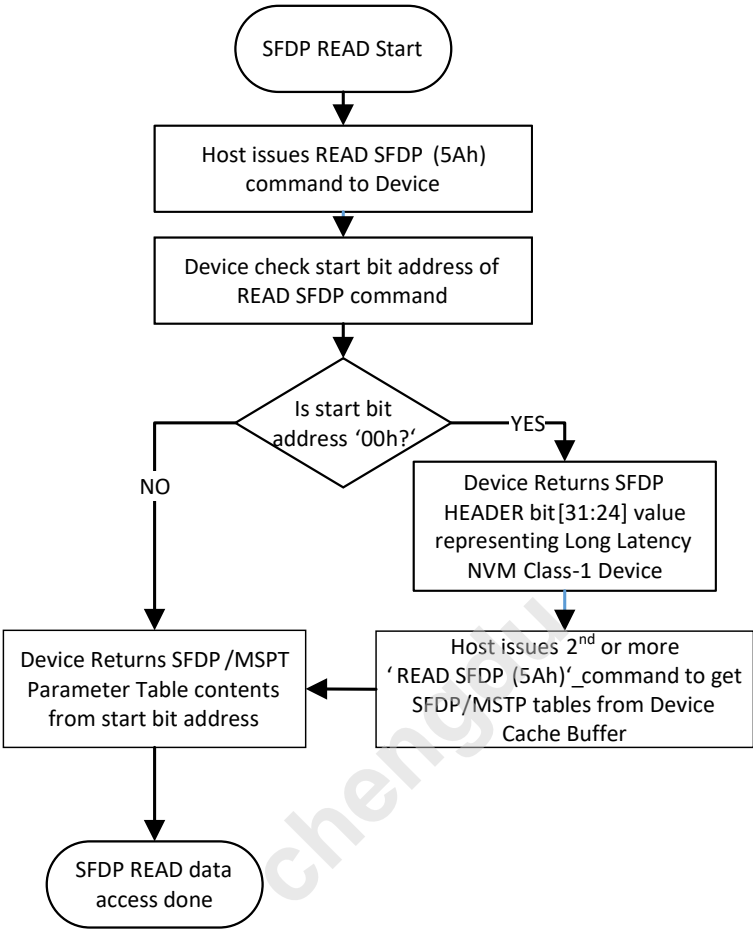

Figure 11 — xSPI NAND Class-1 Device Read SFDP Flow

6.2.3 Definition of SFDP Access Protocol Field (cont'd)

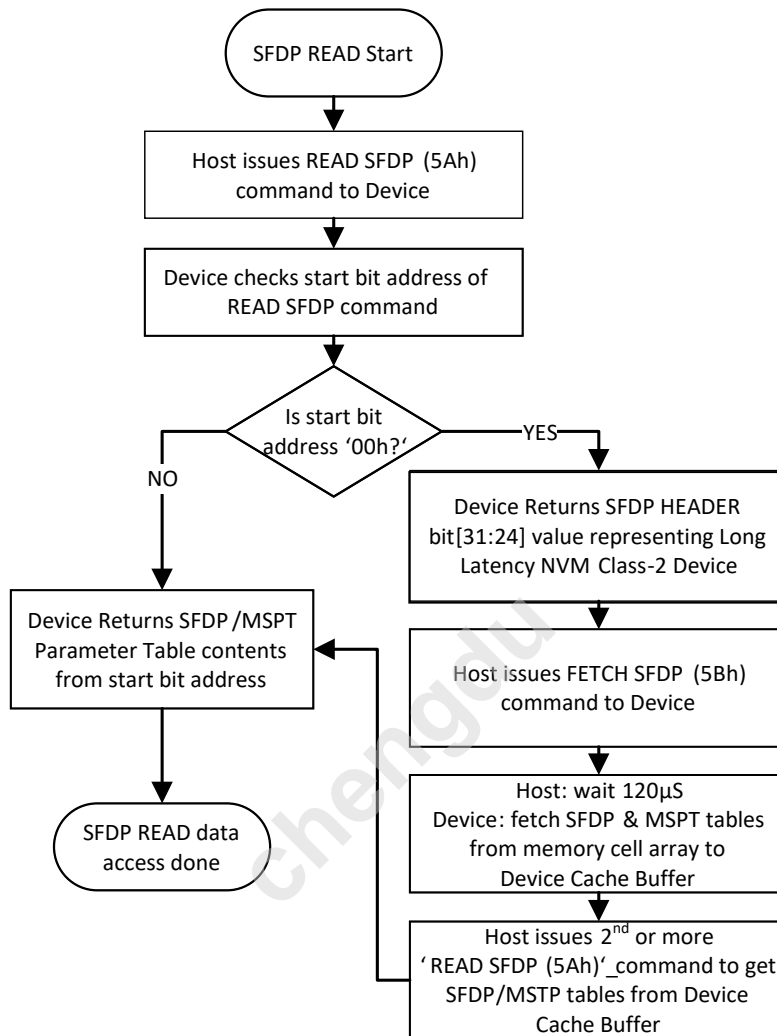

Figure 12 — xSPI NAND Class-2 Device Read SFDP Flow

6.3 Parameter Headers

Each Parameter Header identifies the size, location, revision, ownership and function of their associated parameter tables. Parameter table ownership will be either JEDEC (via this standard) or an individual vendor (via vendor specific documentation).

Multiple parameter headers can be specified with each parameter header being 2 DWORDs (64-bits). The first parameter header is mandatory, is defined by this standard, and starts at byte offset 08h. If a vendor chooses to include multiple revisions of the Basic Parameter Table, they may do so provided the table headers are in order starting with the oldest version. The total number of parameter headers is specified in the NPH field of the SFDP header, see 6.2.2. All subsequent parameter headers need to be contiguous and may be specified by JEDEC or by vendors using the same structure (shown in Figure 10). Minor revisions may overlap earlier revisions by starting at the same address as an earlier revision but have additional length for parameters added in the later revision. This allows the use of legacy parameters without the need to repeat them in each new minor revision.

6.3.1 Parameter Header: 1st DWORD

Bits	Description
31:24	Parameter Table Length This field specifies how many DWORDs are in the Parameter table. NOTE This field is 1's based. Therefore, 1 indicates 1 DWORD.
23:16	Parameter Table Major Revision Number¹ This 8-bit field indicates the major revision number of the associated parameter table. NOTE Major Revision starts at 01h. The Major Revision of JEDEC defined parameter tables can only be modified by updates to this standard. The Major Revision of a vendor-specified table is controlled by that vendor.
15:8	Parameter Table Minor Revision Number¹ This 8-bit field indicates the minor revision number of the associated parameter table. NOTE Minor Revision starts at 00h. The Minor Revision of the JEDEC owned parameter tables can only be modified by updates to this standard. The Minor Revision of a vendor-specified table is controlled by that vendor.
7:0	Parameter ID LSB: Refer to Definition of Parameter ID Field in 6.3.3.

NOTE See "Major vs. Minor Revisions" in 6.2.

6.3.2 Parameter Header: 2nd DWORD

Bits	Description
31:24	Parameter ID MSB Refer to Definition of Parameter ID Field in 6.3.3.
23:0	Parameter Table Pointer (PTP) This address specifies the start of this header's Parameter Table in the SFDP structure. This

Bits	Description
	is a byte address and must be DWORD-aligned.

6.3.3 Definition of Parameter ID Field

The Parameter ID indicates the parameter table ownership and type.

Parameter ID MSB	Parameter ID LSB	Type	Owner
01h – 7Fh	odd parity	Vendor specific	Vendor
01h – 7Fh	even parity	Function specific	Vendor
80h – FFh	even parity	Function specific	JEDEC JC-42.4
FFh	00h	Basic Parameter Table	JEDEC JC-42.4

Function Specific tables may be defined by the JC-42.4 Committee or a manufacturer (vendor). The purpose of the Function Specific tables is to allow development of features and associated parameter tables common to multiple manufacturers, prior to the parameter tables being incorporated into the next revision of JESD216. Allocation of IDs for Function Specific tables is requested through the JEDEC office, see Annex A.

chengdu

6.3.3 Definition of Parameter ID Field (cont'd)

Vendor Specific table structure is defined by the identified device vendor. The parameter table ID field identifies the vendor that owns the table definition.

The original JESD216 specification used only a one byte ID field to identify the parameter table owner. JESD216 revision A expanded the ID field to two bytes, MSB and LSB, because a single byte is insufficient to uniquely identify all manufacturers (vendors). The original single byte parameter ID is now referred to as the parameter ID LSB.

The Parameter ID LSB value of 00h is reserved for the Basic Parameter Table defined by this standard. For backwards compatibility the MSB is FFh when the LSB is 00h and LSB 00h shall not be used when the MSB is any value other than FFh. This is because some legacy systems using the original JESD216 specification may ignore the MSB and assume any parameter ID with LSB of 00h is the Basic Parameter Table.

Parameter IDs with:

- An MSB of 01h through 7Fh indicates a Vendor Owned table and provides the bank number of a JEDEC JEP106 assigned Manufacturer ID.
 - 00h is reserved because JEP106 bank numbering begins at 01h
 - The JEP106 Manufacturer's Identification Code LSB is an eight (8) bit field, consisting of seven (7) data bits plus one (1) odd parity bit in the most significant bit position. A Parameter ID LSB with odd parity signifies a Manufacturer's Identification Code and a Parameter ID LSB with even parity signifies a Function Specific table.
- An MSB of 80h through FFh indicates a Function Specific or Basic Parameter Table defined by the JEDEC 42.4 committee. The LSB is used to identify the Function Specific table type.
 - Any parameter ID with LSB 00h identifies the SPI protocol Basic Parameter Table.
 - LSB values with even parity are Function Specific tables that are defined by the JC-42.4 committee.
 - LSB values with odd parity are illegal to prevent any confusion with JEP106 manufacturer ID values.

6.3.3.1 Function Specific parameter table ID assignments

Description	ID (Hex)
Basic SPI protocol	FF00
Sector map	FF81
Replay Protected Monotonic Counters (RPMC)	FF03
4-byte Address Instruction Table	FF84
eXpanded Serial Peripheral Interface (xSPI) Profile 1.0	FF05
eXpanded Serial Peripheral Interface (xSPI) Profile 2.0	FF06
Status, Control and Configuration Register Map	FF87
Status, Control and Configuration Register Map Offsets for Multi-Chip SPI Memory Devices	FF88
Status, Control and Configuration Register Map for xSPI Profile 2.0	FF09
Command Sequences to change to Octal DDR (8D-8D-8D) mode	FF0A
Long Latency NVM Media Specific Parameter Table (MSPT)	FF8B
x4 Quad IO with DS	FF0C
Command Sequences to change to Quad DDR (4S-4D-4D) mode	FF8D
Secure Packet Read / Secure Packet Write	FF8E
Reserved for next Function Specific Table assignment	FF0F

6.3.4 Example SFDP Headers

Note the definition and discussion of Parameter Headers in paragraph 6.3.

Figure 13 shows an example of a basic SFDP Header (major revision 1, minor revision 7): one Parameter Header, Parameter Table length of 16 DWORDS, 1st Parameter Header Revision 1.7, JEDEC ID of FF00h, and the Parameter Table Pointer pointing to location 000010h. This header is backwards compatible with previous generations of this standard, therefore devices are not required to contain headers with prior revision numbers.

Figure 14 shows the same example as in Figure 13 but with Word based addressing (instead of byte) as needed for xSPI Profile 2.0.

In Figure 15, the first parameter header points to a version 1.0 format Basic Parameter Table of 9 DWORDS starting at location 100h and the second parameter headers both points to a separate version 1.6 format Basic Parameter Table of 16 DWORDS starting at location 200h.

Figure 16 adds one of the Optional Function Specific headers introduced in JESD216B. This third header indicates that this device supports 4-byte address instructions functionality.

In Figure 15 and Figure 16, devices that do not have the functionality of these features may not contain these additional parameters.

Example calculation using the Parameter Table Pointer (PTP):

The PTP is a byte address. The fields within this document are defined in terms of DWORDS.

To calculate the byte address of a particular field, given a PTP of 100h:

The SFDP byte address of the 3rd DWORD = $100h + ((3-1) * 4) = 100h + 2 * 4 = 100h + 8 = 108h$

6.3.4 Example SFDP Headers (cont'd)

For xSPI Profile 2.0, the PTP is a word address. The fields within this document are defined in terms of DWORDS.

To calculate the word address of a particular field, given a PTP of 100h:

The SFDP word address of the 3rd DWORD = $100h + ((3-1) * 2) = 100h + 1 * 4 = 100h + 4 = 104h$

	[31:24]	[23:16]	[15:8]	[7:0]	Hex Byte Location
SFDP Header	50h	44h	46h	53h	< [3h:0h]
	FFh	00h	01h	06h	< [7h:4h]
1st Parameter Header	10h	01h	06h	00h	< [Bh:8h]
	FFh	00h	00h	10h	< [Fh:Ch]

Figure 13 — Example SFDP Header with single Basic Parameter Table

	[31:24]	[23:16]	[15:8]	[7:0]	Hex Word Location
SFDP Header	50h	44h	46h	53h	< [1h:0h]
	FFh	00h	01h	06h	< [3h:2h]
1st Parameter Header	10h	01h	06h	00h	< [5h:4h]
	FFh	00h	00h	10h	< [7h:6h]

Figure 14 — Example SFDP Header with single Basic Parameter Table Word based (xSPI Profile 2.0)

	[31:24]	[23:16]	[15:8]	[7:0]	Hex Byte Location
SFDP Header	50h	44h	46h	53h	< [3h:0h]
	FFh	01h	01h	06h	< [7h:4h]
1st Parameter Header	09h	01h	00h	00h	< [Bh:8h]
	FFh	00h	01h	00h	< [Fh:Ch]
2nd Parameter Header	10h	01h	06h	00h	< [13h:10h]
	FFh	00h	02h	00h	< [17h:14h]

Figure 15 — Example SFDP Header with two Basic parameter Tables

6.3.4 Example SFDP Headers (cont'd)

	[31:24]	[23:16]	[15:8]	[7:0]	Hex Byte Location
SFDP Header	50h	44h	46h	53h	< [3h:0h]
	FFh	02h	01h	06h	< [7h:4h]
1st Parameter Header	09h	01h	00h	00h	< [Bh:8h]
	FFh	00h	01h	00h	< [Fh:Ch]
2nd Parameter Header	10h	01h	06h	00h	< [13h:10h]
	FFh	00h	02h	00h	< [17h:14h]
3rd Parameter Header	02h	01h	00h	84h	< [1Bh:18h]
	FFh	00h	02h	80h	< [1Fh:1Ch]

Figure 16 — Example SFDP Header with two basic Parameter Tables and one optional (4-Byte Address) Function Specific Tables

	[31:24]	[23:16]	[15:8]	[7:0]	Hex Byte Location
SFDP Header	50h	44h	46h	53h	< [3h:0h]
	FFh	02h	01h	06h	< [7h:4h]
1st Parameter Header	09h	01h	00h	00h	< [Bh:8h]
	FFh	00h	01h	00h	< [Fh:Ch]
2nd Parameter Header	10h	01h	06h	00h	< [13h:10h]
	FFh	00h	02h	00h	< [17h:14h]
3rd Parameter Header	02h	01h	01h	84h	< [1Bh:18h]
	FFh	00h	02h	80h	< [1Fh:1Ch]
4th Parameter Header	07	01h	00h	06h	< [23h:20h]
	FFh	00h	03h	00h	< [27h:24h]

Figure 17 — Example SFDP Header with two basic Parameter Tables and two optional (4-Byte Address and Status, Control and Configuration Register Map) Function Specific Tables

6.4 JEDEC Basic Flash Parameter Header and Table

Parameter tables contain coded information describing the features and capabilities of the serial flash. The first parameter table as defined by JEDEC is mandatory and its starting address is specified by the PTP field of the 1st Parameter Header. This table identifies some of the basic features of SPI protocol flash memory devices.

6.4.1 JEDEC Basic Flash Parameter Header: 1st DWORD

Bits	Description
31:24	<p>Parameter Table Length This field specifies how many DWORDs are in the Parameter table. NOTE This field is 1's based. Therefore, 1 indicates 1 DWORD. For the JESD216E revision, this parameter table length is 20 (unchanged from JESD216D revision)</p>
23:16	<p>Parameter Table Major Revision Number This 8-bit field indicates the major revision number of the parameter table. The value in this field is 01h for this table defined by JESD216E revision (unchanged from JESD216D revision). NOTE The Major Revision of JEDEC defined parameter tables can only be modified by updates to this standard.</p>
15:8	<p>Parameter Table Minor Revision Number This 8-bit field indicates the minor revision number of the JEDEC Basic Flash Parameter table. The value in this field is 07h for this table defined by JESD216E revision (unchanged from JESD216D revision). NOTE The Minor Revision of the JEDEC owned parameter tables can only be modified by updates to this standard.</p>
7:0	<p>Parameter ID LSB The JEDEC Basic Flash Parameter Table is assigned the ID LSB of 00h.</p>

6.4.2 JEDEC Basic Flash Parameter Header: 2nd DWORD

Bits	Description
31:24	<p>Parameter ID MSB The JEDEC Basic Flash Parameter Table is assigned the ID MSB of FFh.</p>
23:0	<p>Parameter Table Pointer (PTP) This address specifies the start of this header's Parameter Table in the SFDP structure. The address is in terms of bytes and must be DWORD-aligned.</p>

6.4.3 JEDEC Basic Flash Parameter Table Overview

DWORD	Description
1	Uniform 4KB Sectors, Write Buffer Size, Volatile Status Register, Fast Read Support (1-1-2) (1-2-2) (1-4-4)(1-1-4), Number of Address Bytes, DTR Support
2	Memory Density
3	Fast Read (1-4-4) (1-1-4): Wait States, Mode Bit Clocks, Instruction
4	Fast Read (1-1-2) (1-2-2): Wait States, Mode Bit Clocks, Instruction
5	Fast Read (2-2-2) (4-4-4) Support
6	Fast Read (2-2-2): Wait States, Mode Bit Clocks, Instruction
7	Fast Read (4-4-4): Wait States, Mode Bit Clocks, Instruction
8	Erase Type 1 & 2 Size and Instruction
9	Erase Type 3 & 4 Size and Instruction
10	Erase Type (1:4) Typical Erase Times and Multiplier Used To Derive Max Erase Times
11	Chip Erase Typical Time, Byte Program and Page Program Typical Times, Page Size
12	Erase/Program Suspend/Resume Support, Intervals, Latency, Keep Out Area Size
13	Program/Erase Suspend/Resume Instructions
14	Deep Power-down and Status Register Polling Device Busy
15	Hold and WP Disable Function, Quad Enable Requirements, 4-4-4 Mode Enable/Disable Sequences, 0-4-4 Entry/Exit Methods and Support
16	32-bit Address Entry/Exit Methods and Support, Soft Reset and Rescue Sequences, Volatile and Nonvolatile Status Register Support
17	Fast Read (1-8-8) (1-1-8): Wait States, Mode Bit Clocks, Instruction
18	Octal commands, Byte order, Data strobe, JEDEC SPI Protocol Reset
19	Octal Enable Requirements, 8-8-8 Mode Enable/Disable Sequences, 0-8-8 Entry/Exit Methods and Support
20	Maximum operating speeds

6.4.4 JEDEC Basic Flash Parameter Table: 1st DWORD

Bits	Description
31:23	Unused Contains FFh and can never be changed.
22	Supports (1-1-4) Fast Read Device supports single input instruction & address and quad output data Fast Read. 0: (1-1-4) Fast Read NOT supported. 1: (1-1-4) Fast Read supported.
21	Supports (1-4-4) Fast Read Device supports single input instruction, quad input address, and quad output data Fast Read. 0: (1-4-4) Fast Read NOT supported. 1: (1-4-4) Fast Read supported.
20	Supports (1-2-2) Fast Read Device supports single input instruction, dual input address, and dual output data Fast Read. 0: (1-2-2) Fast Read NOT supported. 1: (1-2-2) Fast Read supported.
19	Supports Double Transfer Rate (DTR) Clocking Indicates the device supports some type of double transfer rate clocking. 0: DTR NOT supported 1: DTR Clocking supported
18:17	Address Bytes Number of bytes used in addressing flash array read, write and erase: 00b: 3-Byte only addressing 01b: 3- or 4-Byte addressing (e.g., defaults to 3-Byte mode; enters 4-Byte mode on command) 10b: 4-Byte only addressing 11b: Reserved NOTE This field refers to the number of address bits/bytes that are clocked in for any command requiring an address except for SFDP Header or Table accesses. All SFDP accesses use 3-byte addressing. A device using 4-byte only addressing may still support 03h read using 3-byte addressing. Examples: Read, Fast Read, Write, 4 kilobyte Erase.
16	Supports (1-1-2) Fast Read Device supports single input instruction & address and dual output data Fast Read with 8 wait states. 0: (1-1-2) Fast Read NOT supported. 1: (1-1-2) Fast Read supported.
15:8	4 Kilobyte Erase Instruction NOTE If 4 kilobyte erase is not supported, then enter FFh. This instruction must also be included in one of the Erase Types in 6.4.8 or 0

Bits	Description
7:5	<p>Unused</p> <p>Contains 111b and can never be changed.</p>
4	<p>Write Enable Instruction Select for Writing to Volatile Status Register This bit only applies if bit 3 is 1.</p> <p>0: flash device requires instruction 50h as the write enable prior to performing a volatile write to the status register</p> <p>1: flash device requires instruction 06h as the write enable prior to performing a volatile write to the status register.</p> <p>NOTE If target flash status register is nonvolatile, then bits 3 and 4 must be set to 00b. This bit definition is maintained for legacy compatibility only. New system implementations should refer to 6.4.19 for a full definition of volatile and non-volatile behavior.</p>
3	<p>Volatile Status Register Block Protect bits</p> <p>0: Block Protect bits in device's status register are solely non-volatile or may be programmed either as volatile using the 50h instruction for write enable or non-volatile using the 06h instruction for write enable.</p> <p>1: Block Protect bits in device's status register are solely volatile.</p> <p>NOTE If target flash register is nonvolatile, then bits 3 and 4 must be set to 00b. This bit definition is maintained for legacy compatibility only. New devices should refer to 6.4.19 for a full definition of volatile and non-volatile behavior.</p>
2	<p>Write Granularity</p> <p>0: 1 Byte – Use this setting for single byte programmable devices or buffer programmable devices when the buffer is less than 64 bytes (32 Words).</p> <p>1: Use this setting for buffer programmable devices when the buffer size is 64 bytes (32 Words) or larger.</p> <p>This bit definition is maintained for legacy compatibility only. New system implementations should refer to 6.4.14 for the buffer (page) size. The legacy minimum write granularity is a single byte within any size programming buffer.</p>
1:0	<p>Block/Sector Erase Sizes</p> <p>Identifies if the device supports uniform 4k erase blocks. This erase size information must also be included one of the Erase Types in 6.4.11 or 6.4.12.</p> <p>00b: Reserved</p> <p>01b: 4 kilobyte Erase is supported throughout the device</p> <p>10b: Reserved</p> <p>11b: Use this setting only if uniform 4 kilobyte erase is unavailable.</p> <p>NOTE This is a legacy field. Refer to sections 6.4.8 and 0 for information on what erase sizes are supported.</p>

6.4.5 JEDEC Basic Flash Parameter Table: 2nd DWORD

Bits	Description
31:0	<p>Flash Memory Density For densities 2 gigabits or less, bit-31 is set to 0b. The field 30:0 defines the size in bits. Example: 00FFFFFFh = 16 megabits</p> <p>For densities 4 gigabits and above, bit-31 is set to 1b. The field 30:0 defines 'N' where the density is computed as 2^N bits (N must be >= 32). Example: 80000021h = 2³³ = 8 gigabits</p>

6.4.6 JEDEC Basic Flash Parameter Table: 3rd DWORD

Bits	Description
31:24	<p>(1-1-4) Fast Read Instruction Instruction for single input instruction & address and quad output data Fast Read.</p>
23:21	<p>(1-1-4) Fast Read Number of Mode Clocks This field will be 000b if Mode Bits are not supported,</p> <p>NOTE This field should be counted in clocks not number of bits received by the serial flash. The initiator drives the bus during "mode bits" cycles; the initiator tri-states the bus during "dummy" cycles.</p> <p>Example: If 4 mode bits are needed with a single input address phase command, this field would be 100b.</p>
20:16	<p>(1-1-4) Fast Read Number of Wait states (dummy clocks) needed before valid output This field will be 00000b if wait states/dummy clocks are not supported. (The number of dummy clocks should be > 0 to avoid contention on bi-directional pins.)</p> <p>Example: If 8 bits are needed with a single input address phase command, this field would be 01000b.</p>
15:8	<p>(1-4-4) Fast Read Instruction Instruction for single input instruction, quad input address, and quad output data Fast Read.</p>
7:5	<p>Quad Input Address Quad Output (1-4-4) Fast Read Number of Mode Clocks This field will be 000b if Mode bits are not supported,</p> <p>NOTE This field should be counted in clocks not number of bits received by the serial flash. The initiator drives the bus during "mode bits" cycles; the initiator tri-states the bus during "dummy" cycles.</p> <p>Example: If 8 mode bits are needed with a quad input address phase command, this field would be 010b.</p>
4:0	<p>(1-4-4) Fast Read Number of Wait states (dummy clocks) needed before valid output This field will be 00000b if wait states/dummy clocks are not supported. (The number of dummy clocks should be > 0 to avoid contention on bi-directional pins.)</p> <p>Example: If 16 bits are needed with a quad input address phase command, this field would be 00100b.</p>

6.4.7 JEDEC Basic Flash Parameter Table: 4th DWORD

Bits	Description
31:24	<p>(1-2-2) Fast Read Instruction Instruction for single input instruction, dual input address, and dual output data Fast Read.</p>
23:21	<p>(1-2-2) Fast Read Number of Mode Clocks This field will be 000b if Mode bits are not supported,</p> <p>NOTE This field should be counted in clocks not number of bits received by the serial flash. The initiator drives the bus during "mode bits" cycles; the initiator tri-states the bus during "dummy" cycles.</p> <p>Example: If 8 mode bits are needed with a dual input address phase command, this field would be 100b.</p>
20:16	<p>(1-2-2) Fast Read Number of Wait states (dummy clocks) needed before valid output This field will be 00000b if wait states/dummy clocks are not supported. (The number of dummy clocks should be > 0 to avoid contention on bi-directional pins.)</p> <p>Example: If 8 bits are needed with a dual input address phase command, this field would be 00100b.</p>
15:8	<p>(1-1-2) Fast Read Instruction Instruction for single input instruction& address and dual output data Fast Read. Note: The industry standard is 3Bh</p>
7:5	<p>(1-1-2) Fast Read Number of Mode Clocks This field will be 000b if Mode bits are not supported,</p> <p>NOTE This field should be counted in clocks not number of bits received by the serial flash.</p> <p>Example: If 4 mode bits are needed with a single input address phase command, this field would be 100b.</p>
4:0	<p>(1-1-2) Fast Read Number of Wait states (dummy clocks) needed before valid output This field should be programmed with 01000b for 8 clocks of dummy cycle. (The number of dummy clocks should be > 0 to avoid contention on bi-directional pins.)</p> <p>NOTE For legacy reasons, if dummy clocks for this instruction is not 01000b, then bit 16 in 6.4.1 (Supports (1-1-2) Fast Read with 8 wait states) must NOT be set to '1'.</p>

6.4.8 JEDEC Basic Flash Parameter Table: 5th DWORD

Bits	Description
31:5	Reserved. These bits default to all 1's
4	<p>Supports (4-4-4) Fast Read Device supports Quad input instruction & address and quad output data Fast Read.</p> <p>0: (4-4-4) Fast Read NOT supported. 1: (4-4-4) Fast Read supported.</p>
3:1	Reserved. These bits default to all 1's
0	<p>Supports (2-2-2) Fast Read Device supports dual input instruction& address and dual output data Fast Read.</p> <p>0: (2-2-2) Fast Read NOT supported. 1: (2-2-2) Fast Read supported.</p>

6.4.9 JEDEC Basic Flash Parameter Table: 6th DWORD

Bits	Description
31:24	<p>(2-2-2) Fast Read Instruction Instruction for dual input instruction& address and dual output data Fast Read.</p>
23:21	<p>(2-2-2) Fast Read Number of Mode Clocks This field will be 000b if Mode bits are not supported,</p> <p>NOTE This field should be counted in clocks not number of bits received by the serial flash. The initiator drives the bus during "mode bits" cycles; the initiator tri-states the bus during "dummy" cycles.</p> <p>Example: If 4 mode bits are needed with a (2-2-2) Fast Read command, this field would be 010b.</p>
20:16	<p>(2-2-2) Fast Read Number of Wait states (dummy clocks) needed before valid output This field will be 00000b if wait states/dummy clocks are not supported. (The number of dummy clocks should be > 0 to avoid contention on bi-directional pins.)</p> <p>Example: If 8 bits are needed with a (2-2-2) Fast Read command, this field would be 00100b.</p>
15:0	Reserved. These bits default to all 1's

6.4.10 JEDEC Basic Flash Parameter Table: 7th DWORD

Bits	Description
31:24	(4-4-4) Fast Read Instruction Instruction for quad input instruction/address, quad output data Fast Read.
23:21	(4-4-4) Fast Read Number of Mode Clocks This field will be 000b if Mode bits are not supported, NOTE This field should be counted in clocks not number of bits received by the serial flash. The initiator drives the bus during "mode bits" cycles; the initiator tri-states the bus during "dummy" cycles. Example: If 8 mode bits are needed with a (4-4-4) Fast Read phase command, this field would be 010b.
20:16	(4-4-4) Fast Read Number of Wait states (dummy clocks) needed before valid output This field will be 00000b if wait states/dummy clocks are not supported. (The number of dummy clocks should be > 0 to avoid contention on bi-directional pins.) Example: If 16 bits are needed with a (4-4-4) Fast Read phase command, this field would be 00100b.
15:0	Reserved. These bits default to all 1's

6.4.11 JEDEC Basic Flash Parameter Table: 8th DWORD

NOTE If the device uses a 4k subsector size, that size and instruction must be included somewhere in the 8th or 9th DWORD. This allows the user to discover the typical and maximum erase times for the 4k subsector by referencing the 10th DWORD.

Bits	Description
31:24	Erase Type 2 Instruction Instruction used to erase the number of bytes specified by Erase Type 2 Size (bits 23-16).
23:16	Erase Type 2 Size: This field will be 00h if this erase type does not exist. NOTE This field specifies 'N' and is used to calculate erase type size = 2 ^N bytes Example: If the erase type size is 32 kilobytes, this field would 0Fh.
15:8	Erase Type 1 Instruction Instruction used to erase the number of bytes specified by Erase Type 1 Size (bits 7-0).
7:0	Erase Type 1 Size NOTE This field specifies 'N' and is used to calculate erase type size = 2 ^N bytes Example: If the erase type size is 4 kilobytes, this field would 0Ch.

6.4.12 JEDEC Basic Flash Parameter Table: 9th DWORD

Bits	Description
31:24	Erase Type 4 Instruction Instruction used to erase the number of bytes specified by Erase Type 4 Size (bits 23-16).
23:16	Erase Type 4 Size This field will be 00h if this erase type does not exist. NOTE This field specifies 'N' and is used to calculate erase type size = 2 ^N bytes Example: If the erase type size is 256 kilobytes, this field would 12h.
15:8	Erase Type 3 Instruction Instruction used to erase the number of bytes specified by Erase Type 3 Size (bits 7-0).
7:0	Erase Type 3 Size This field will be 00h if this erase type does not exist. NOTE This field specifies 'N' and is used to calculate erase type size = 2 ^N bytes Example: If the erase type size is 64 kilobytes, this field would 10h.

6.4.13 JEDEC Basic Flash Parameter Table: 10th DWORD

Bits	Description
31:25	Erase Type 4 Erase, Typical time Time the device <i>typically</i> takes to erase a Erase Type 4 size, see 0. User must poll device busy to determine if the operation has completed. This field has no meaning if the Erase Type 4 size is 00h. 31:30 units (00b: 1 ms, 01b: 16 ms, 10b: 128 ms, 11b: 1 s) 29:25 count Formula: typical time = (count + 1)*units Example: If count=2 and units=10b, then typical time is (2+1)*128ms = 384 ms The range is 1ms to 32 seconds in four groups: 1 ms to 32 ms, 16 ms to 512 ms, 128 ms to 4096 ms, 1 s to 32 s
24:18	Erase Type 3 Erase, Typical time Time the device <i>typically</i> takes to erase a Erase Type 3 size, see 0. User must poll device busy to determine if the operation has completed. This field has no meaning if the Erase Type 3 size is 00h. 24:23 units (00b: 1 ms, 01b: 16 ms, 10b: 128 ms, 11b: 1 s) 22:18 count Formula: typical time = (count + 1)*units Example: If count=1 and units=10b, then typical time is (1+1)*128ms = 256 ms The range is 1ms to 32 seconds in four groups: 1 ms to 32 ms, 16 ms to 512 ms, 128 ms to 4096 ms, 1 s to 32 s

17:11	<p>Erase Type 2 Erase, Typical time</p> <p>Time the device <i>typically</i> takes to erase a Erase Type 2 size, see 6.4.8. User must poll device busy to determine if the operation has completed. This field has no meaning if the corresponding Erase Type size is 00h.</p> <p>17:16 units (00b: 1 ms, 01b: 16 ms, 10b: 128 ms, 11b: 1 s) 15:11 count</p> <p>Formula: typical time = (count + 1)*units Example: If count=0 and units=10b, then typical time is (0+1)*128ms = 128 ms The range is 1ms to 32 seconds in four groups: 1 ms to 32 ms, 16 ms to 512 ms, 128 ms to 4096 ms, 1 s to 32 s</p>
10:4	<p>Erase Type 1 Erase, Typical time</p> <p>Time the device <i>typically</i> takes to erase a Erase Type 1 size, see 6.4.8. User must poll device busy to determine if the operation has completed. This field has no meaning if the corresponding Erase Type size is 00h.</p> <p>10:9 units (00b: 1 ms, 01b: 16 ms, 10b: 128 ms, 11b: 1 s) 8:4 count</p> <p>Formula: typical time = (count + 1)*units Example: If count=1 and units=10b, then typical time is 1*128ms = 128 ms The range is 1ms to 32 seconds in four groups: 1 ms to 32 ms, 16 ms to 512 ms, 128 ms to 4096 ms, 1 s to 32 s</p>
3:0	<p>Multiplier from typical erase time to maximum erase time</p> <p>3:0 count</p> <p>Formula: Erase Type n (or Chip) erase maximum time = 2 * (count + 1) * Erase Type n (or Chip) erase typical time Example: If count = 9, then Erase Type n (or Chip) erase maximum time is 20 * Sector Type n (or Chip) erase typical time</p> <p>NOTE 1 'n' = 1, 2, 3, or 4 NOTE 2 This multiplier applies to all erase types and the chip erase. The maximum time is intended to be used as a watchdog timeout for an error or failure condition. Since a common scale factor is used across all erase sizes, any particular maximum time may only approximate the datasheet maximum time.</p>

6.4.14 JEDEC Basic Flash Parameter Table: 11th DWORD

Bits	Description
31	Reserved
30:24	<p>Chip Erase, Typical time Typical time to erase one chip (die). User must poll device busy to determine if the operation has completed. For a device consisting of multiple die, that are individually accessed, the time is for each die to which a chip erase command is applied.</p> <p>30:29 units (00b: 16 ms, 01b: 256 ms, 10b: 4 s, 11b: 64 s) 28:24 count</p> <p>Formula: typical time = (count + 1)*units</p> <p>Example: If count=5 and units=10b, then typical time is: 5*4 s = 20 s The range of this field is 16ms to 2048 seconds in four groups: 16 ms to 512 ms, 256 ms to 8192 ms, 4 s to 128 s, 64 s to 2048 s</p>
23:19	<p>Byte Program Typical time, additional byte Time the device <i>typically</i> takes to write each additional byte after the first. User must poll device busy to determine if the operation has completed.</p> <p>23 units (0: 1 μs, 1: 8 μs) 22:19 count</p> <p>Formula: additional byte time = (count + 1)*units/byte Example: If units = 1 and count =4, then each additional byte typically adds (4+1)*8 μs = 40 μs to the programming time. For 16 bytes, the additional time would be 16 * 40 μs = 640 μs</p> <p>The range is 1 μs to 128 μs in two groups: 1 μs to 16 μs and 8 μs to 128 μs.</p> <p>NOTE The programming time for small numbers of bytes does not scale linearly up to a full page programming time. When the number of bytes being programmed exceeds ½ of a page size, users should base estimates on the Page Program typical time in this DWORD.</p>
18:14	<p>Byte Program Typical time, first byte Time the device <i>typically</i> takes to write the first byte in a sequence. User must poll device busy to determine if the operation has completed.</p> <p>18 units (0: 1 μs, 1: 8 μs) 17:14 count</p> <p>Formula: first byte typical time = (count + 1)*units Example: If units = 0 and count = 7, then typical time is (7+1)*1 μs = 8 μs The range is 1 μs to 128 μs in two groups: 1 μs to 16 μs and 8 μs to 128 μs</p>

13:8	<p>Page Program Typical time Time the device <i>typically</i> takes to write a full page. User must poll device busy to determine if the operation has completed. The user may scale this by ½ or ¼ to determine approximate times for ½ and ¼ page program operations</p> <p>13 units (0: 8 µs, 1: 64 µs) 12:8 count</p> <p>Formula: typical page program time = (count + 1)*units The range is 8 µs to 2048 µs in two groups: 8 µs to 256 µs and 64 µs to 2048 µs</p>
7:4	<p>Page Size This field specifies 'N' and is used to calculate page size = 2^N bytes.</p>
3:0	<p>Multiplier from typical time to max time for Page or byte program</p> <p>3:0 count</p> <p>Formula: maximum time = 2 * (count + 1)*typical time</p> <p>NOTE This multiplier applies to all page or byte typical program times. The maximum time is intended to be used as a watchdog timeout for an error or failure condition. Since a common scale factor is used across all program sizes, any particular maximum time may only approximate the datasheet maximum time.</p>

6.4.15 JEDEC Basic Flash Parameter Table: 12th DWORD

Bits	Description
31	<p>Suspend / Resume supported The device supports suspend and resume of both program and erase operations. 0: supported 1: not supported</p>
30:24	<p>Suspend in-progress erase max latency Maximum time required by the flash device to suspend an in-progress erase and be ready to accept another command which accesses the flash array. This time does not apply to the read status command. See also <i>Suspend in-progress program in this DWORD</i>.</p> <p>30:29 units (00b: 128ns, 01b: 1µs, 10b: 8µs, 11b: 64µs) 28:24 count</p> <p>Formula: erase max latency = (count + 1)*units Example: if units =01b and count =19, then erase max latency = (19+1)*1 µs = 20 µs The range is 128 ns to 2048 µs in four groups: 128 ns to 4.096 µs, 1 µs to 32 µs, 8 µs to 256 µs, 64 µs to 2048 µs</p>
23:20	<p>Erase Resume to Suspend Interval The device requires this typical amount of time to make progress on the erase before allowing another suspend. It is possible to immediately suspend again after a resume -- there is no required minimum time between resuming an operation and suspending the operation again. However, the device requires some average amount of active operation time, after a resume, to make progress on the operation, before another suspend. This parameter recommends an average interval of time that should be allowed between a resume and the next suspend in order for the operation to eventually complete. If there are some intervals less than the recommended value there should be a similar number of intervals that are longer than the recommended value. If the interval is consistently less than the recommended value the operation may never finish.</p> <p>23:20 count of fixed units of 64µs</p> <p>Formula: erase resume to suspend interval = (count + 1)*64 µs Example: if count = 7, the erase resume to suspend interval = (7+1)*64 µs = 512 µs The range is 64 µs to 1024 µs</p>
19:13	<p>Suspend in-progress program max latency Maximum time required by the flash device to suspend an in-progress program and be ready to accept another command which accesses the flash array. This time does not apply to the read status command. See also <i>Suspend in-progress erase in this DWORD</i>.</p> <p>19:18 units (00b: 128ns, 01b: 1µs, 10b: 8µs, 11b: 64µs) 17:13 count</p> <p>Formula: suspend in-progress program max latency = (count+1)*units Example: if units = 01b and count = 4, then suspend in-progress program max latency = (4+1)*1 µs = 5 µs The range is 128 ns to 2048 µs in four groups: 128 ns to 4.096 µs, 1 µs to 32 µs, 8 µs to 256 µs, and 64 µs to 2048 µs.</p>

<p>12:9</p>	<p>Program Resume to Suspend Interval The device requires this typical amount of time to make progress on the program operation before allowing another suspend. It is possible to immediately suspend again after a resume -- there is no required minimum time between resuming an operation and suspending the operation again. However, the device requires some average amount of active operation time, after a resume, to make progress on the operation, before another suspend. This parameter recommends an average interval of time that should be allowed between a resume and the next suspend in order for the operation to eventually complete. If there are some intervals less than the recommended value there should be a similar number of intervals that are longer than the recommended value. If the interval is consistently less than the recommended value the operation may never finish.</p> <p>12:9 count of fixed units of 64 μs</p> <p>Formula: program resume to suspend interval = (count + 1)*64 μs Example: if count = 15, the erase resume to suspend interval = (15+1)*64 μs = 1024 μs The range is 64 μs to 1024 μs</p>
<p>8</p>	<p>Reserved</p>
<p>7:4</p>	<p>Prohibited Operations During Erase Suspend</p> <p>xxx0b: May not initiate a new erase anywhere (erase nesting not permitted) xxx1b: May not initiate a new erase in the erase suspended erase type size xx0xb: May not initiate a page program anywhere xx1xb: May not initiate a page program in the erase suspended erase type size x0xxb: Refer to vendor datasheet for read restrictions x1xxb: May not initiate a read in the erase suspended erase type size 0xxxb: Additional erase or program restrictions apply 1xxxb: The erase and program restrictions in bits 5:4 are sufficient</p> <p>NOTE This list is not comprehensive. Consult the device datasheet for a full list of allowed and prohibited operations.</p>
<p>3:0</p>	<p>Prohibited Operations During Program Suspend</p> <p>xxx0b: May not initiate a new erase anywhere (erase nesting not permitted) xxx1b: May not initiate a new erase in the program suspended page size xx0xb: May not initiate a new page program anywhere (program nesting not permitted) xx1xb: May not initiate a new page program in the program suspended page size x0xxb: Refer to vendor datasheet for read restrictions x1xxb: May not initiate a read in the program suspended page size 0xxxb: Additional erase or program restrictions apply 1xxxb: The erase and program restrictions in bits 1:0 are sufficient</p> <p>NOTE This list is not comprehensive. Consult the device datasheet for a full list of allowed and prohibited operations.</p>

6.4.16 JEDEC Basic Flash Parameter Table: 13th DWORD

Bits	Description
31:24	Suspend Instruction Instruction used to suspend a write or erase type operation.
23:16	Resume Instruction Instruction used to resume a write or erase type operation.
15:8	Program Suspend Instruction Instruction used to suspend a program operation. (If the device requires a unique instruction to suspend a "program" command then that instruction is listed here. Otherwise this field contains the same value as the "Suspend Instruction" field above.)
7:0	Program Resume Instruction Instruction used to resume a program operation. (If the device requires a unique instruction to resume a "program" command then that instruction is listed here. Otherwise this field contains the same value as the "Resume Instruction" field above.)

chengdu

6.4.17 JEDEC Basic Flash Parameter Table: 14th DWORD

Bits	Description
31	<p>Deep Powerdown Supported 0: supported 1: not supported</p>
30:23	<p>Enter Deep Powerdown Instruction Instruction used to enter deep powerdown</p>
22:15	<p>Exit Deep Powerdown Instruction Instruction used to exit deep powerdown</p>
14:8	<p>Exit Deep Powerdown to next operation delay Maximum time required by the flash device to exit Deep Powerdown and be ready to accept any command. (Note: Read status is not valid when exiting deep powerdown.)</p> <p>14:13 units (00b: 128ns, 01b: 1µs, 10b: 8µs, 11b: 64µs) 12:8 count</p> <p>Formula: exit Deep Powerdown to next operation delay = (count+1)*units Example: if units = 10b and count = 4, then delay = (4+1)*8 µs = 40 µs The range is 128 ns to 2048 µs in four groups: 128 ns to 4.096 µs, 1 µs to 32 µs, 8 µs to 256 µs, and 64 µs to 2048 µs</p>
7:2	<p>Status Register Polling Device Busy This bit field defines various ways the flash device's busy status may be polled. A zero in a bit position indicates that the device does not support the particular polling method.</p> <p>1x_xxxxb: Reserved x1_xxxxb: Reserved xx_1xxxxb: Reserved xx_x1xxb: Reserved</p> <p>xx_xx1xb: Bit 7 of the Flag Status Register may be polled any time a Program, Erase, Suspend/Resume command is issued, or after a Reset command while the device is busy. The read instruction is 70h. Flag Status Register bit definitions: bit[7]: Program or erase controller status (0=busy; 1=ready)</p> <p>xx_xxx1b: Use of legacy polling is supported by reading the Status Register with 05h instruction and checking WIP bit[0] (0=ready; 1=busy).</p>
1:0	<p>Reserved</p>

6.4.18 JEDEC Basic Flash Parameter Table: 15th DWORD

Bits	Description
31:24	Reserved
23	<p>HOLD or RESET Disable</p> <p>Defines whether HOLD or RESET may be disabled via a configuration register</p> <p>If driving IO3 high during command phase HOLD or RESET do not need to be disabled. Device decodes instruction to determine functionality of HOLD/RESET vs. data</p> <p>1: set bit 4 of the Non-Volatile Extended Configuration Register = 0 to disable HOLD or RESET 0: above feature is not supported</p>
22:20	<p>Quad Enable Requirements (QER)</p> <p>This field describes whether the device contains a Quad Enable (QE) bit used to enable 1-1-4 and 1-4-4 quad read or quad program operations. If QE exists, this field also identifies the bit location and method to set/clear the bit.</p> <p>In this standard, status register 1 refers to the first data byte transferred on a Read Status (05h) or Write Status (01h) command. Status register 2 refers to the byte read using instruction 35h. Status register 2 is the second byte transferred in a Write Status (01h) command. Bits are numbered from 7 to 0, where bit 7 is transferred first on the wire.</p> <p>NOTE Industry naming and definitions of these status registers may differ. The user will typically perform a read-modify-write sequence of operations to maintain the state of all other writable status register bits. For example read both status registers, set/clear QE, Write Status with both data bytes.</p> <p>000b: Device does not have a QE bit. Device detects 1-1-4 and 1-4-4 reads based on instruction. IO3/HOLD# functions as hold during instruction phase.</p> <p>001b: QE is bit 1 of status register 2. It is set via Write Status with two data bytes where bit 1 of the second byte is one. It is cleared via Write Status with two data bytes where bit 1 of the second byte is zero. Writing only one byte to the status register has the side-effect of clearing status register 2, including the QE bit. The 100b code is used if writing one byte to the status register does not modify status register 2.</p> <p>010b: QE is bit 6 of status register 1. It is set via Write Status with one data byte where bit 6 is one. It is cleared via Write Status with one data byte where bit 6 is zero.</p> <p>011b: QE is bit 7 of status register 2. It is set via Write status register 2 instruction 3Eh with one data byte where bit 7 is one. It is cleared via Write status register 2 instruction 3Eh with one data byte where bit 7 is zero. The status register 2 is read using instruction 3Fh.</p> <p>100b: QE is bit 1 of status register 2. It is set via Write Status with two data bytes where bit 1 of the second byte is one. It is cleared via Write Status with two data bytes where bit 1 of the second byte is zero. In contrast to the 001b code, writing one byte to the status register does not modify status register 2.</p> <p>101b: QE is bit 1 of the status register 2. Status register 1 is read using Read Status instruction 05h. Status register 2 is read using instruction 35h. QE is set via Write Status instruction 01h with two data bytes where bit 1 of the second byte is one. It is cleared via Write Status with two data bytes where bit 1 of the second byte is zero.</p> <p>110b: QE is bit 1 of the status register 2. Status register 1 is read using Read Status instruction 05h. Status register 2 is read using instruction 35h, and status register 3 is read using instruction 15h. QE is set via Write Status Register instruction 31h with one data byte where bit 1 is one. It is cleared via Write Status Register instruction 31h with one data byte where bit 1 is zero.</p> <p>111b: Reserved</p>

19:16	<p>0-4-4 Mode Entry Method</p> <p>xxx1b: Mode Bits[7:0] = A5h Note: QE must be set prior to using this mode</p> <p>xx1xb: Read the 8-bit volatile configuration register with instruction 85h, set XIP bit[3] in the data read, and write the modified data using the instruction 81h, then Mode Bits [7:0] = 01h</p> <p>x1xxb: Mode Bit[7:0]=AXh</p> <p>lxxxb: Reserved</p>
15:10	<p>0-4-4 Mode Exit Method</p> <p>xx_xxx1b: Mode Bits[7:0] = 00h will terminate this mode at the end of the current read operation</p> <p>xx_xx1xb: If 3-Byte address active, input Fh on IO0-IO3 for 8 clocks. If 4-Byte address active, input Fh on IO0-IO3 for 10 clocks. This will terminate the mode prior to the next read operation.</p> <p>xx_x1xxb: Reserved</p> <p>xx_lxxxb: Input Fh (mode bit reset) on IO0-IO3 for 8 clocks. This will terminate the mode prior to the next read operation.</p> <p>x1_xxxxb: Mode Bit[7:0] ≠ AXh</p> <p>lx_xxxxb: Reserved</p>
9	<p>0-4-4 mode supported</p> <p>This mode is variously referred to as implied instruction, continuous read, execute in place, etc.</p> <p>0: not supported</p> <p>1: supported</p>
8:4	<p>4-4-4 mode enable sequences</p> <p>This field describes the supported methods to enter 4-4-4 mode from 1-1-1 mode.</p> <p>x_xxx1b: set QE per QER description above, then issue instruction 38h</p> <p>x_xx1xb: issue instruction 38h</p> <p>x_x1xxb: issue instruction 35h</p> <p>x_lxxxb: device uses a read-modify-write sequence of operations: read configuration using instruction 65h followed by address 800003h, set bit 6, write configuration using instruction 71h followed by address 800003h. This configuration is volatile.</p> <p>l_xxxxb: 4-4-4 mode enable sequences Device uses a read-modify-write sequence of operations: Read Volatile Enhanced Configuration Register using instruction 65h, no address is required, reset bit 7 to 0. Write Volatile Enhanced Configuration Register using instruction 61h, no address is required. This configuration is volatile.</p> <p>4-4-4 mode disable sequences device uses a read-modify-write sequence of operations: Read Volatile Enhanced Configuration Register using instruction 65h, no address is required, set bit 7 to 1. Write Volatile Enhanced Configuration Register using instruction 61h, no address is required. This configuration is volatile.</p> <p>NOTE If device is in 0-4-4 mode, then this mode must be exited before the 4-4-4 enable sequence is issued.</p>
3:0	<p>4-4-4 mode disable sequences</p> <p>This field describes the supported methods to exit 4-4-4 mode.</p> <p>xxx1b: issue FFh instruction</p> <p>xx1xb: issue F5h instruction</p> <p>x1xxb: device uses a read-modify-write sequence of operations: read configuration using instruction 65h followed by address 800003h, clear bit 6, write configuration using instruction 71h followed by address 800003h. This configuration is volatile.</p> <p>lxxxb: issue the Soft Reset 66/99 sequence, see 6.4.19</p> <p>NOTE If device is in 0-4-4 mode, then this mode must be exited before the 4-4-4 disable sequence is issued.</p>

6.4.19 JEDEC Basic Flash Parameter Table: 16th DWORD

Bits	Description
31:24	<p>Enter 4-Byte Addressing</p> <p>This field defines the supported methods to enter 4-byte addressing mode or to use an extended address register with 3-byte addressing to access memory above 16 MBytes.</p> <p>xxxx_xxx1b: issue instruction B7h (preceding write enable not required)</p> <p>xxxx_xx1xb: issue write enable instruction 06h, then issue instruction B7h</p> <p>xxxx_x1xxb: 8-bit volatile extended address register used to define A[31:24] bits. Read with instruction C8h. Write instruction is C5h with 1 byte of data. Select the active 128 Mbit memory segment by setting the appropriate A[31:24] bits and use 3-Byte addressing.</p> <p>xxxx_1xxxb: 8-bit volatile bank register used to define A[30:A24] bits. MSB (bit[7]) is used to enable/disable 4-byte address mode. When MSB is set to '1', 4-byte address mode is active and A[30:24] bits are don't care. Read with instruction 16h. Write instruction is 17h with 1 byte of data. When MSB is cleared to '0', select the active 128 Mbit segment by setting the appropriate A[30:24] bits and use 3-Byte addressing.</p> <p>xxx1_xxxxb: A 16-bit nonvolatile configuration register controls 3-Byte/4-Byte address mode. Read instruction is B5h. Bit[0] controls address mode [0=3-Byte; 1=4-Byte]. Write configuration register instruction is B1h, data length is 2 bytes.</p> <p>xx1x_xxxxb: Supports dedicated 4-Byte address instruction set. Consult vendor data sheet for the instruction set definition.</p> <p>x1xx_xxxxb: Always operates in 4-Byte address mode</p> <p>1xxx_xxxxb: Reserved</p>
23:14	<p>Exit 4-Byte Addressing</p> <p>xx_xxxx_xxx1b: issue instruction E9h to exit 4-Byte address mode (write enable instruction 06h is not required)</p> <p>xx_xxxx_xx1xb: issue write enable instruction 06h, then issue instruction E9h to exit 4-Byte address mode</p> <p>xx_xxxx_x1xxb: 8-bit volatile extended address register used to define A[31:A24] bits. Read with instruction C8h. Write instruction is C5h, data length is 1 byte. Return to lowest memory segment by setting A[31:24] to 00h and use 3-Byte addressing.</p> <p>xx_xxxx_1xxxb: 8-bit volatile bank register used to define A[30:A24] bits. MSB (bit[7]) is used to enable/disable 4-byte address mode. When MSB is cleared to '0', 3-byte address mode is active and A30:A24 are used to select the active 128 Mbit memory segment. Read with instruction 16h. Write instruction is 17h, data length is 1 byte.</p> <p>xx_xxx1_xxxxb: A 16-bit nonvolatile configuration register controls 3-Byte/4-Byte address mode. Read instruction is B5h. Bit[0] controls address mode [0=3-Byte; 1=4-Byte]. Write configuration register instruction is B1h, data length is 2 bytes.</p> <p>xx_xx1x_xxxxb: Hardware reset</p> <p>xx_x1xx_xxxxb: Software reset (see bits 13:8 in this DWORD)</p> <p>xx_1xxx_xxxxb: Power cycle</p> <p>x1_xxxx_xxxxb: Reserved</p> <p>1x_xxxx_xxxxb: Reserved</p>

13:8	<p>Soft Reset and Rescue Sequence Support This field specifies how to return the device to its default power-on state.</p> <p>00_0000b: no software reset instruction is supported xx_0001b: drive Fh on all 4 data wires for 8 clocks xx_0010b: drive Fh on all 4 data wires for 10 clocks if device is operating in 4-byte address mode xx_0100b: drive Fh on all 4 data wires for 16 clocks xx_1000b: issue instruction F0h x1_0000b: issue reset enable instruction 66h, then issue reset instruction 99h. The reset enable, reset sequence may be issued on 1, 2, 4, or 8 wires depending on the device operating mode. 1x_0000b: exit 0-4-4 mode is required prior to other reset sequences above if the device may be operating in this mode. See 6.4.18, 0-4-4 Mode Exit</p>
7	<p>Reserved</p>
6:0	<p>Volatile or Non-Volatile Register and Write Enable Instruction for Status Register 1 The instruction 01h is typically used to write status register 1 which contains Block Protection (BP) and other bits. Status register 1 is written by the first data byte following the instruction 01h. The protection bits must be written to zero to enable writes/erases to the device. This field describes how to modify the writable bits in status register 1 in either a volatile or non-volatile manner. Bits 1:0 in status register 1 are de-facto standard write enable and busy status and are excluded from the definitions below.</p> <p>xxx_0001b: Non-Volatile Status Register 1, powers-up to last written value, use instruction 06h to enable write xxx_0010b: Volatile Status Register 1, status register powers-up with bits set to "1"s, use instruction 06h to enable write xxx_0100b: Volatile Status Register 1, status register powers-up with bits set to "1"s, use instruction 50h to enable write xxx_1000b: Non-Volatile/Volatile status register 1 powers-up to last written value in the non-volatile status register, use instruction 06h to enable write to non-volatile status register. Volatile status register may be activated after power-up to override the non-volatile status register, use instruction 50h to enable write and activate the volatile status register. xx1_0000b: Status Register 1 contains a mix of volatile and non-volatile bits. The 06h instruction is used to enable writing of the register. x1x_0000b: Reserved 1xx_0000b: Reserved</p> <p>NOTE If the status register is read-only then this field will contain all zeros in bits 4:0.</p>

6.4.20 JEDEC Basic Flash Parameter Table: 17th DWORD

Bits	Description
31:24	<p>(1-1-8) Fast Read Instruction Instruction for single input instruction & address and octal output data Fast Read. If this field is 0x00, (1-1-8) Fast Read is not supported</p>
23:21	<p>(1-1-8) Fast Read Number of Mode Clocks This field will be 000b if Mode Bits are not supported. NOTE This field should be counted in clocks not number of bits received by the serial flash. The initiator drives the bus during "mode bits" cycles; the initiator tri-states the bus during "dummy" cycles. Example: If 4 mode bits are needed with a single input address phase command, this field would be 100b.</p>
20:16	<p>(1-1-8) Fast Read Number of Wait states (dummy clocks) needed before valid output This field will be 00000b if wait states/dummy clocks are not supported. (The number of dummy clocks should be > 0 to avoid contention on bi-directional pins.) Example: If 8 bits are needed with a single input address phase command, this field would be 01000b.</p>
15:8	<p>(1-8-8) Fast Read Instruction Instruction for single input instruction, octal input address, and octal output data Fast Read. If this field is 0x00, (1-8-8) Fast Read is not supported</p>
7:5	<p>(1-8-8) Fast Read Number of Mode Clocks This field will be 000b if Mode bits are not supported. NOTE This field should be counted in clocks not number of bits received by the serial flash. The initiator drives the bus during "mode bits" cycles; the initiator tri-states the bus during "dummy" cycles. Example: If 8 mode bits are needed with a octal input address phase command, this field would be 001b.</p>
4:0	<p>(1-8-8) Fast Read Number of Wait states (dummy clocks) needed before valid output This field will be 00000b if wait states/dummy clocks are not supported. (The number of dummy clocks should be > 0 to avoid contention on bi-directional pins.) Example: If 16 bits are needed with a octal input address phase command, this field would be 00010b.</p>

6.4.21 JEDEC Basic Flash Parameter Table: 18th DWORD

Bits	Description
31	<p>Byte Order in 8D-8D-8D mode 0b: Byte order of 16-bit words is the same when read in 1-1-1 mode and 8D-8D-8D mode. 1b: Byte order of 16-bit words is swapped when read in 8D-8D-8D mode compared to 1-1-1 mode.</p>
30-29	<p>Octal DTR (8D-8D-8D) Command and Command Extension 00b: The Command Extension is the same as the Command. (The Command / Command Extension has the same value for the whole clock period.) 01b: Command Extension is the inverse of the Command. The Command Extension acts as a confirmation of the Command 10b: Reserved 11b: Command and Command Extension forms a 16 bit command word.</p>
28	<p>Reserved. Leave as “0”. (This allows new features to be added to these bits in the future.)</p>
27	<p>Data Strobe support for QPI DTR mode (4S-4D-4D) 0b: DS is not supported for QPI DTR mode 1b: DS is supported for QPI DTR mode</p>
26	<p>Data Strobe support for QPI STR mode (4S-4S-4S) 0b: DS is not supported for QPI STR mode 1b: DS is supported for QPI STR mode</p>
25:24	<p>Data Strobe Waveforms in STR Mode 11b: First rising edge of DS half a clock cycle before the start of the first data bit, start of first data bit aligned with the first falling edge of DS, first rising edge of DS follows a rising edge of CK, as shown in Error! Reference source not found. 10b: First rising edge of DS in the middle of the first data bit, start of second data bit aligned with the first falling edge of DS, first rising edge of DS follows a Rising edge of CK, as shown in Figure 19 01b: Start of first data bit aligned with the first rising edge of DS, first rising edge of DS follows a falling edge of CK, as shown in Figure 20 00b: Reserved</p>
23	<p>JEDEC SPI Protocol Reset (In-Band Reset) 0: JEDEC SPI Protocol Reset NOT implemented 1: JEDEC SPI Protocol Reset implemented as described in JESD252.</p>
22:18	<p>Variable Output Driver Strength Mainly used for devices supporting the xSPI spec, but may also be used for other devices. See the xSPI spec for definition of driver strengths. See Section 6.10.28 for a description of the control bits used to select driver type. 00000b: Not supported xxxx1: Driver Type 0 Supported (This option is required for devices supporting the xSPI spec) xxx1x: Driver Type 1 Supported xx1xx: Driver Type 2 Supported x1xxx: Driver Type 3 Supported 1xxxx: Driver Type 4 Supported</p>
17:0	<p>Reserved. Leave as “0”. (This allows new features to be added to these bits in the future.)</p>

6.4.21 JEDEC Basic Flash Parameter Table: 18th DWORD (cont'd)

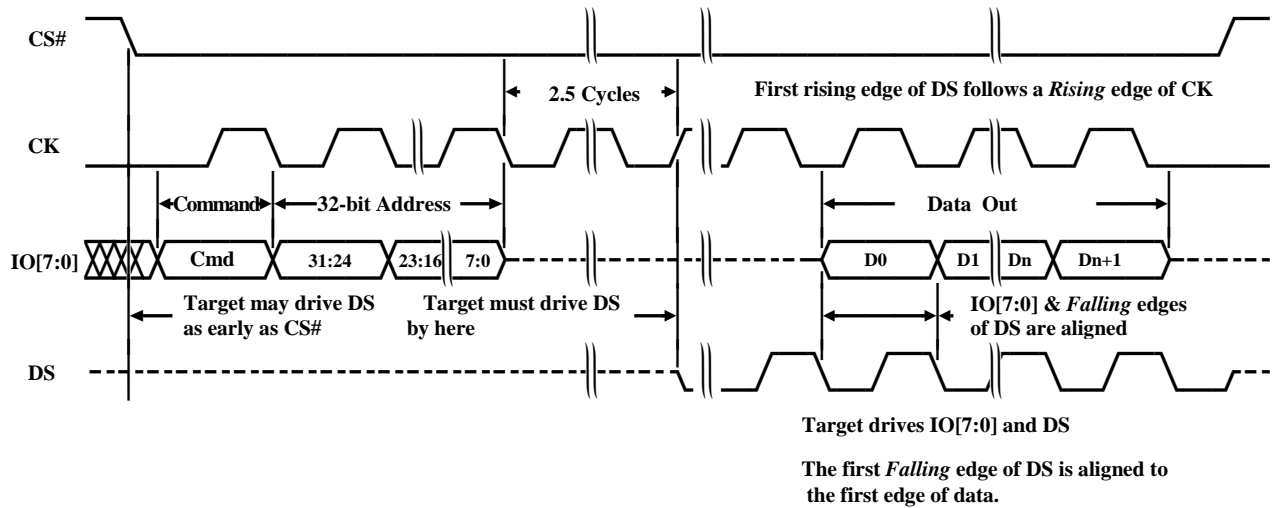

Figure 18 — Data Strobe Waveforms in STR Mode – Option 11b

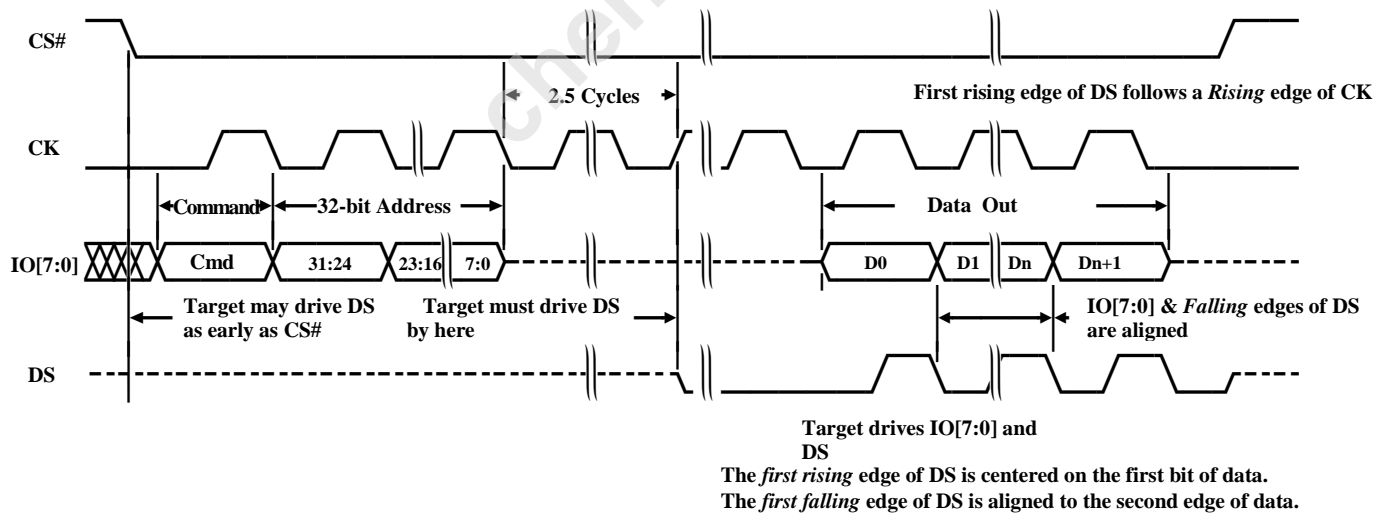

Figure 19 — Data Strobe Waveforms in STR Mode - Option 10b

6.4.21 JEDEC Basic Flash Parameter Table: 18th DWORD (cont'd)

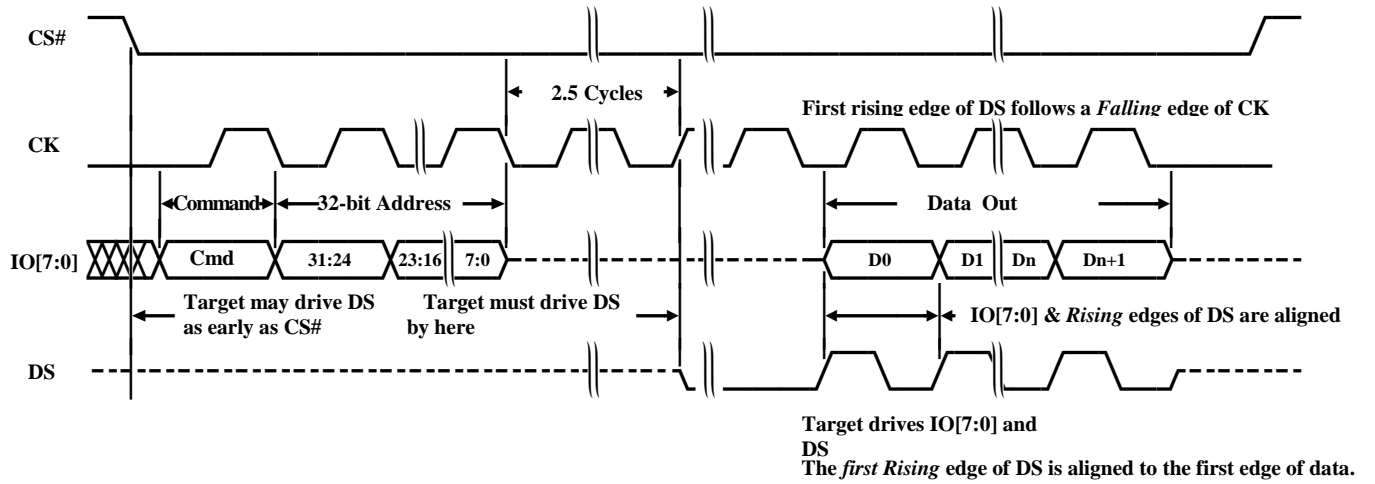

Figure 20 — Data Strobe Waveforms in STR Mode - Option 01b

6.4.22 JEDEC Basic Flash Parameter Table: 19th DWORD

Bits	Description
31:23	Reserved. Leave as “0”. (This allows new features to be added to these bits in the future.)
22:20	<p>Octal Enable Requirements:</p> <p>This field describes whether the device contains a Octal Enable bit used to enable 1-1-8 and 1-8-8 octal read or octal program operations. If Octal Enable exists, this field also identifies the bit location and method to set/clear the bit.</p> <p>The methods used for accessing Status/Configuration Registers differ between vendors, and are therefore described in detail.</p> <p>NOTE Industry naming and definitions of these status registers may differ. The user will typically perform a read-modify-write sequence of operations to maintain the state of all other writable status register bits. For example read both status registers, set/clear Octal Enable, Write Status with both data bytes.</p> <p>000b: Device does not have an Octal Enable bit.</p> <p>001b: Octal Enable is bit 3 of status register 2. It is set via Write status register 2 instruction 31h with one data byte where bit 3 is one. It is cleared via Write status register 2 instruction 3Eh with one data byte where bit 3 is zero. The status register 2 is read using instruction 65h with address byte 02h and one dummy byte.</p> <p>010b-111b: Reserved</p>
19:16	<p>0-8-8 Mode Entry Method:</p> <p>0000b: Device does not support 0-8-8 mode</p> <p>xxx1b: Read the 8-bit volatile configuration register with instruction 85h, set XIP bit[0] in the data read, and write the modified data using the instruction 81h, then Mode Bits [7:0] = 01h</p> <p>xx1xb, x1xxb, 1xxx: Others</p>
15:10	<p>0-8-8 Mode Exit Method</p> <p>00 0000b: Device does not support 0-8-8 mode</p> <p>xx xxx1b: Mode Bits[7:0] = 00h will terminate this mode at the end of the current read operation</p> <p>xx xx1xb: If 3-Byte address active, input FFh on DQ0-DQ7 for 4 clocks. If 4-Byte address active, input Fh on DQ0-DQ7 for 5 clocks. This will terminate the mode prior to the next read operation.</p> <p>xx x1xxb – 1x xxxxb: Others</p>
9	<p>0-8-8 mode supported</p> <p>This mode is variously referred to as implied instruction, continuous read, execute in place, etc.</p> <p>0: not supported</p> <p>1: supported</p>
8:4	<p>8s-8s-8s mode enable sequences</p> <p>This field describes the supported methods to enter 8-8-8 mode from 1-1-1 mode.</p> <p>x_xx1xb: x_xx1xb: Issue instruction 06h (WREN), then issue instruction E8h</p> <p>x_x1xxb: Issue instruction 06h (WREN), then issue instruction 72h (Write CFG Reg 2), Address = 00000000h, Data = 01h (8S-8S-8S) or 02h (8D-8D-8D)</p>
3:0	<p>8s-8s-8s mode disable sequences</p> <p>This field describes the supported methods to exit 8-8-8 mode.</p> <p>xxx1b: Issue instruction 06h (WREN), then issue FFh instruction</p> <p>1xxx: Issue the Soft Reset 66/99 sequence, see 6.4.19</p>

6.4.23 JEDEC Basic Flash Parameter Table: 20th DWORD

Bits	Description
31:28	<p>Maximum operation speed of device in 8D-8D-8D mode when utilizing Data Strobe</p> <p>1111b: 8D-8D-8D mode using Data Strobe is not supported 1110b: 8D-8D-8D mode using Data Strobe is not characterized 1010b: Reserved 1100b: 400 MHz* 1011b: 333 MHz* 1010b: 266 MHz* 1001b: 250 MHz* 1000b: 200 MHz 0111b: 166 MHz 0110b: 133 MHz 0101b: 100 MHz 0100b: 80 MHz 0011b: 66 MHz 0010b: 50 MHz 0001b: 33 MHz 0000b: Reserved</p> <p>* Operation faster than 200MHz is not part of the current xSPI Spec. However, this does not prevent vendors from making devices that operate at higher speed.</p>
27:24	<p>Maximum operation speed of device in 8D-8D-8D mode when not utilizing Data Strobe</p> <p>1111b: 8D-8D-8D mode without using Data Strobe is not supported 1110b: 8D-8D-8D mode without using Data Strobe is not characterized 1010b: Reserved 1100b: 400 MHz* 1011b: 333 MHz* 1010b: 266 MHz* 1001b: 250 MHz* 1000b: 200 MHz 0111b: 166 MHz 0110b: 133 MHz 0101b: 100 MHz 0100b: 80 MHz 0011b: 66 MHz 0010b: 50 MHz 0001b: 33 MHz 0000b: Reserved</p>
23:20	<p>Maximum operation speed of device in 8S-8S-8S mode when utilizing Data Strobe</p> <p>1111b: 8S-8S-8S mode using Data Strobe is not supported 1110b: 8S-8S-8S mode using Data Strobe is not characterized 1010b: Reserved 1100b: 400 MHz 1011b: 333 MHz 1010b: 266 MHz 1001b: 250 MHz 1000b: 200 MHz 0111b: 166 MHz 0110b: 133 MHz 0101b: 100 MHz 0100b: 80 MHz 0011b: 66 MHz 0010b: 50 MHz 0001b: 33 MHz 0000b: Reserved</p>

6.4.23 JEDEC Basic Flash Parameter Table: 20th DWORD (cont'd)

Bits	Description
19:16	<p>Maximum operation speed of device in 8S-8S-8S mode when not utilizing Data Strobe</p> <p>1111b: 8S-8S-8S mode without using Data Strobe is not supported 1110b: 8S-8S-8S mode without using Data Strobe is not characterized 1010b: Reserved 1100b: 400 MHz* 1011b: 333 MHz* 1010b: 266 MHz* 1001b: 250 MHz* 1000b: 200 MHz 0111b: 166 MHz 0110b: 133 MHz 0101b: 100 MHz 0100b: 80 MHz 0011b: 66 MHz 0010b: 50 MHz 0001b: 33 MHz 0000b: Reserved</p>
15:12	<p>Maximum operation speed of device in 4S-4D-4D mode when utilizing Data Strobe</p> <p>1111b: 4S-4D-4D mode using Data Strobe is not supported 1110b: 4S-4D-4D mode using Data Strobe is not characterized 1010b: Reserved 1100b: 400 MHz 1011b: 333 MHz 1010b: 266 MHz 1001b: 250 MHz 1000b: 200 MHz 0111b: 166 MHz 0110b: 133 MHz 0101b: 100 MHz 0100b: 80 MHz 0011b: 66 MHz 0010b: 50 MHz 0001b: 33 MHz 0000b: Reserved</p>
11:8	<p>Maximum operation speed of device in 4S-4D-4D mode when not utilizing Data Strobe</p> <p>1111b: 4S-4D-4D mode without using Data Strobe is not supported 1110b: 4S-4D-4D mode without using Data Strobe is not characterized 1010b: Reserved 1100b: 400 MHz* 1011b: 333 MHz* 1010b: 266 MHz* 1001b: 250 MHz* 1000b: 200 MHz 0111b: 166 MHz 0110b: 133 MHz 0101b: 100 MHz 0100b: 80 MHz 0011b: 66 MHz 0010b: 50 MHz 0001b: 33 MHz 0000b: Reserved</p>

6.4.23 JEDEC Basic Flash Parameter Table: 20th DWORD (cont'd)

Bits	Description
7:4	<p>Maximum operation speed of device in 4S-4S-4S mode when utilizing Data Strobe</p> <p>1111b: 4S-4S-4S mode using Data Strobe is not supported 1110b: 4S-4S-4S mode using Data Strobe is not characterized 1010b - 1000b: Reserved 0111b: 166 MHz 0110b: 133 MHz 0101b: 100 MHz 0100b: 80 MHz 0011b: 66 MHz 0010b: 50 MHz 0001b: 33 MHz 0000b: Reserved</p>
3:0	<p>Maximum operation speed of device in 4S-4S-4S mode when not utilizing Data Strobe</p> <p>1111b: 4S-4S-4S mode without using Data Strobe is not supported 1110b: 4S-4S-4S mode without using Data Strobe is not characterized 1010b: Reserved 1100b: 400 MHz * 1011b: 333 MHz * 1010b: 266 MHz * 1001b: 250 MHz * 1000b: 200 MHz 0111b: 166 MHz 0110b: 133 MHz 0101b: 100 MHz 0100b: 80 MHz 0011b: 66 MHz 0010b: 50 MHz 0001b: 33 MHz 0000b: Reserved</p>

6.5 JEDEC Sector Map Parameter Header and Table

A sector is the minimum size and alignment (granularity) of an area that can be erased in the data array of a flash memory device. Different areas within the address range of the data array may have a different minimum erase granularity (sector size).

The Sector Map Parameter Table identifies the location and size of sectors within the main data array of the flash memory device and identifies which Erase Types are supported by each sector. This table is required when a memory device:

- Has sectors of more than one size, or
- does not allow all Erase Type commands to be applied to all sectors.

When there is more than one sector size in a device, each contiguous group of sectors, that are of the same size, and support the same erase types, is called a region. A region may be as small as a single sector. There are one or more regions for each sector size. There is more than one region of a particular sector size when that sector size appears in more than one area of the address space and these areas are separated by one or more regions of a different sector size. For example: a region of 4KB sectors, followed by a region of 64KB sectors, followed by a region of 4KB sectors.

There may also be more than one region of the same size sector when the regions support different sets of Erase Types. For example: one region of 4KB sectors may support use of Erase Types for 4KB erase and 64KB erase but not 8KB erase or 32KB erase and an adjacent region of 4KB sectors may support all these Erase Types. The Sector Map Parameter Table is used to identify which Erase Type commands may be used within each region.

There may be more than one possible map of sector size, location, or Erase Type support. For example: a memory device may be user configurable to have some small sectors at the top or at the bottom of the address space, with all remaining sectors being a larger size. Because the small sectors may appear at either the top or the bottom of the address space, two sector maps are needed to describe the top or bottom location and size of the smaller sectors.

If there is more than one user selected sector map (configuration), this table includes the definition of instructions needed to determine which sector map configuration is in use. The number of sector map configuration detection commands is variable, the number of configurations is variable, and the number of regions in each configuration is variable, thus the size of this table is variable.

6.5.1 Sector Map Parameter Header: 1st DWORD

Bits	Description
31:24	Parameter Table Length This field specifies how many DWORDs are in the Parameter table. NOTE This field is 1's based. Therefore, 1 indicates 1 DWORD.
23:16	Parameter Table Major Revision Number This 8-bit field indicates the major revision number of the Sector Map parameter table. The value in this field is 01h for this table defined by JESD216E revision (unchanged from JESD216D revision). NOTE The Major Revision of JEDEC defined parameter tables can only be modified by updates to this standard.
15:8	Parameter Table Minor Revision Number This 8-bit field indicates the minor revision number of the Sector Map parameter table. The value in this field is 00h for this table defined by JESD216E revision (unchanged from JESD216D revision). NOTE The Minor Revision of the JEDEC owned parameter tables can only be modified by updates to this standard.
7:0	Parameter ID LSB The Sector Map Function Specific Table is assigned the ID LSB of 81h.

6.5.2 Sector Map Parameter Header: 2nd DWORD

Bits	Description
31:24	Parameter ID MSB The Sector Map Function Specific Table is assigned the ID MSB of FFh.
23:0	Parameter Table Pointer (PTP) This address specifies the start of this header's Parameter Table in the SFDP structure. The address is in terms of bytes and must be DWORD-aligned.

The Sector Map table is built from a sequence of descriptors. There are two types of descriptors:

- A configuration detection command descriptor (command), and
- A configuration sector map descriptor (map).

The command descriptors are optional. If there is a single configuration then no command descriptors are needed. If there are more than two configurations, more than one command descriptor is needed. If command descriptors are provided, they always precede map descriptors in the table.

Each configuration detection command is described by two Dwords. These Dwords provide:

- A bit indicating that the descriptor is a configuration detection command,
- a bit indicating whether this descriptor is the last command descriptor,
- the instruction code for the command,
- the number of address bytes for the command,
- the number of read latency cycles between the last address byte and the read data byte,
- a mask to select the bit of interest in the returned data byte,
- and the address value for the command.

It is assumed that each command is reading a configuration register with a single byte of return data and that this type of command does not provide mode bits. Each command selects a single bit from the byte of returned data. There will be a separate command descriptor and command sent for each bit of configuration selecting information that is needed to select the current Sector Map Configuration that is in use.

6.5.3 Configuration Detection Command Descriptor, 1st DWORD

Bits	Description
31:24	<p>Read data mask Eight bit field with a single bit = 1. The 8 bit field is logically ANDed with the one byte of data read by the configuration detection command specified in this Dword. This bit field is used as a mask to select one bit from the data byte that is read.</p>
23:22	<p>Configuration detection command address length Two bit field that defines the length of the address used in the configuration detection command.</p> <p>00b: No address in the command. 01b: 3 byte address. 10b: 4 byte address 11b: Variable address length (the current setting of the address length mode defines the address length)</p> <p>When the length is defined as variable, the software or hardware controlling the memory is aware of the address length mode last set in the memory device and this same length of address is used in sending the configuration detection command.</p>
21:20	<p>Reserved These bits default to all 1's.</p>
19:16	<p>Configuration detection command read latency, in clock cycles Four bit field indicating the number of cycles between the end of address and the beginning of returning read data.</p> <p>Range from 0 to 14 cycles of read latency (wait states). A value of Fh indicates the read latency is variable. The software or hardware controlling the memory is aware of the latency last set in the memory device and this same value is used in the configuration detection command.</p>
15:8	<p>Detection command instruction. Eight bit instruction for the sector map configuration detection command.</p>
7:2	<p>Reserved These bits default to all 1's.</p>
1	<p>Descriptor Type 0b: Command descriptor 1b: Map descriptor</p>
0	<p>Descriptor Sequence End Indicator 0b: Another descriptor of the same type follows this descriptor 1b: This is the last descriptor of this type.</p>

6.5.4 Configuration Detection Command Descriptor, 2nd DWORD

Bits	Description
31:0	Sector map configuration detection command address Thirty two bit field providing up to 4 bytes of address. The number of address bytes in this field that are used by the command is determined by the address length in bits 23:22 of the first Dword.

The first DWORD of a command descriptor contains a field that identifies it as a command type descriptor. A single bit field in each command descriptor indicates whether it is the last command descriptor in the sequence. Each command descriptor defines the format of a command used to detect the value of one configuration bit in the memory device and has an eight bit mask value used to select a single bit from one data byte read by the command. The second DWORD of each command descriptor provides a 4 byte address that may optionally be used as part of the configuration detection command.

Each configuration bit value detected is part of the selection for the current configuration of the sector map. For example: if there are five to eight possible sector map configurations, at least three configuration detection commands will be needed to extract three bits of configuration selection information from the device in order to identify which configuration is currently in use. The configuration selector is limited to a maximum of 8 bits, allowing for a maximum of 256 possible configurations. However, there may not be a separate configuration needed for every possible value of the selector value. Each detected configuration bit is shifted left into the configuration selector value such that the last detected bit is in the least significant bit of the selector value. If there are no command descriptors provided, because there is a single configuration, the default value of the configuration selector is zero.

Each configuration map descriptor is described by two or more Dwords. These Dwords provide:

- A map header DWORD
 - A bit indicating that the descriptor is a sector map descriptor,
 - a bit indicating whether this descriptor is the last map descriptor,
 - a configuration ID,
 - a count of the regions in the map.
- A DWORD for each region in the map
 - A value indicating the size of the region,
 - bits that indicate which Erase Types are supported in the region.

6.5.5 Configuration Map Descriptor Header DWORD

Bits	Description
31:24	Reserved These bits default to all 1's.
23:16	Region count The number of following region DWORDs minus 1
15:8	Configuration ID A value compared with the configuration selector value to determine if this map descriptor is for the currently selected sector map.
7:2	Reserved These bits default to all 1's.
1	Descriptor Type 0b: Command descriptor 1b: Map descriptor
0	Descriptor Sequence End Indicator 0b: Another descriptor of the same type follows this descriptor 1b: This is the last descriptor of this type.

6.5.6 Region DWORD

Bits	Description
31:8	Region size Region size as a multiple (count) of 256 Byte units. The Region size value is zero based, so a region of 256 Bytes has a size value = 0. Region size value = (count - 1) Region size = (value + 1) * 256 bytes
7:4	Reserved These bits default to all 1's.
3	Erase Type 4 1b: Erase Type 4 erase command is supported in this region 0b: Erase Type 4 erase command is not supported in this region
2	Erase Type 3 1b: Erase Type 3 erase command is supported in this region 0b: Erase Type 3 erase command is not supported in this region
1	Erase Type 2 1b: Erase Type 2 erase command is supported in this region 0b: Erase Type 2 erase command is not supported in this region
0	Erase Type 1 1b: Erase Type 1 erase command is supported in this region 0b: Erase Type 1 erase command is not supported in this region

6.5.6 Region DWORD (cont'd)

At least one map descriptor is required. The first DWORD of a map descriptor is the header for the map and contains a field that identifies it as a map type descriptor. A single bit field in each map descriptor header indicates whether it is the last map descriptor in the sequence. The map descriptor header has a configuration ID field that is matched against the configuration selector value. If the configuration selector matches the configuration ID, the rest of the map descriptor defines the current sector map in use. If the configuration values do not match, the next map descriptor is examined. If there are no more map descriptors and no configuration ID matched the configuration identifier, the sector address map is unknown.

The map descriptor header contains a count of the number of regions in the map. Each region is described by a following DWORD. Each region DWORD indicates the size of sectors in the region and the supported Erase Types for that region. The region count indicates the number of DWORDs to skip when looking for the next map descriptor.

The first region starts at location zero of the data array in the flash device. Each additional region starts at the next higher location than the size of the previous region.

chengdu

6.5.7 Sector Map Parameter Table – Example 1

The memory device in the following example is 256Mbit density and has three user settable sector map configurations. Two configuration detection commands are used to read the sector map related configuration control bits from registers. While there are four possible combinations of the two control bits, only three combinations are valid and only three configuration maps are provided. The three configurations are:

- Eight 4Kbyte sectors at the low address end (bottom) of the device address space, with all other sectors being 64Kbytes in size. Only Erase Type 1 for 4Kbyte sectors are supported in the region of 4Kbyte sectors and only Erase Type 2 for 64Kbyte erase is supported in the region containing 64Kbyte sectors.
- Eight 4Kbyte sectors at the high address end (top) of the device address space, with all other sectors being 64Kbytes in size. Only Erase Type 1 for 4Kbyte sectors are supported in the region of 4Kbyte sectors and only Erase Type 2 for 64Kbyte erase is supported in the region containing 64Kbyte sectors.
- Uniform 64Kbyte sectors with only Erase Type 2 for 64Kbyte sectors supported.

DWORD	Bits				Notes
	31:24	23:16	15:8	7:0	
0	Read Data Mask = 00001000b = 08h	Instruction Format (Address length variable = 11b [2 bits] Reserved = 11b [2 bits] Latency cycles variable = 1111b [4 bits]) = FFh	Instruction = 65h	Reserved = 111111b Descriptor type = command = 0b Not the last command = 0b FCh	Configuration Detect Command 1 (2 DWORDs) Instruction 65h, variable address length, variable latency, address 00800004h, select bit 3. Configuration Detection
1	Address Value = 00800004h				
2	Read Data Mask = 00000100b = 04h	Instruction Format (Address length zero = 00b [2 bits] Reserved = 11b [2bits] Latency cycles = 00000b [6 bits] = 20h	Instruction = 35h	Reserved = 111111b Descriptor type = command = 0b Last command = 1b FDh	
3	Address Value = FFFFFFFFh				

4	Reserved = FFh	Region Count = 3 Regions = 02h	Configuration ID = 00h	Reserved = 111111b Descriptor type = map = 1b Last map = 0b FEh	Configuration Map Header	1st Configuration Address Map Bottom: 8x 4KB sectors at bottom, 1x overlaid 64KB sector at bottom, 511 uniform 64KB sectors
5	Region size as count-1 of 256 Byte units [24 bits] 8x 4KB sectors = 32KB, count = 32KB/256 = 128 value = count - 1 = 128 - 1 = 127 = 00007Fh			Reserved = 1111b Supported Sector Type commands bit- field = 0001b Assuming 4KB sector type is assigned to sector type 1 F1h	<- Sector Region 0 only 4KB erase commands supported in this region	
6	Region size as count-1 of 256 Byte units [24 bits] 32KB region, count = 32KB/256 = 128 value = count - 1 = 128 - 1 = 127 = 00007Fh			Reserved = 1111b Supported Sector Type commands bit-field = 0010b Assuming 64KB sector type is assigned to sector type 2 F2h	<- Sector Region 1 only 64KB erase commands supported in this region	
7	Region size as count-1 of 256 Byte units [24 bits] 511 x 64KB sectors, count = 33488896 B/256 = 130816 value = count - 1 = 130816 - 1 = 130815 = 01FEFFh			Reserved = 1111b Supported Sector Type commands bit-field = 0010b Assuming 64KB sector type is assigned to sector type 2 F2h	<- Sector Region 2 only 64KB erase commands supported in this region	
8	Reserved = FFh	Region Count = 3 Regions = 02h	Configuration ID = 01h	Reserved = 111111b Descriptor type = map = 1b Last map = 0b FEh	Configuration Map Header	2nd Configuration Address Map Top: 511x uniform 64KB sectors, 1x

9	<p>Region size as count-1 of 256 Byte units [24 bits] 511 x 64KB sectors, count = $33488896 \text{ B}/256 = 130816$ value = count - 1 = $130816 - 1 = 130815 =$</p> <p>01FEFFh</p>			<p>Reserved = 1111b Supported Sector Type commands bit-field = 0010b Assuming 64KB sector type is assigned to sector type 2</p> <p>F2h</p>	<p><- Sector Region 0</p> <p>only 64KB erase commands supported in this region</p>	<p>overlaid 64KB sector, 8x 4KB sectors at top</p>
10	<p>Region size as count-1 of 256 Byte units [24 bits] 32KB region, count = $32\text{KB}/256 = 128$ value = count - 1 = $128 - 1 = 127 =$</p> <p>00007Fh</p>			<p>Reserved = 1111b Supported Sector Type commands bit-field = 0010b Assuming 64KB sector type is assigned to sector type 2</p> <p>F2h</p>	<p><- Sector Region 1</p> <p>only 64KB erase commands supported in this region</p>	
11	<p>Region size as count-1 of 256 Byte units [24 bits] 8x 4KB sectors = 32KB, count = $32\text{KB}/256 = 128$ value = count - 1 = $128 - 1 = 127 =$</p> <p>00007Fh</p>			<p>Reserved = 1111b Supported Sector Type commands bit-field = 0001b Assuming 4KB sector type is assigned to sector type 1</p> <p>F1h</p>	<p><- Sector Region 2</p> <p>only 4KB erase commands supported in this region</p>	
12	<p>Reserved =</p> <p>FFh</p>	<p>Region Count = 1 Regions =</p> <p>00h</p>	<p>Configuration ID =</p> <p>02h</p>	<p>Reserved = 111111b Descriptor type = map = 1b Last map = 1b</p> <p>FFh</p>	<p>Configuration Map Header</p>	<p>3rd Configuration Address Map Uniform 64KB sectors</p>
13	<p>Region size as count-1 of 256 Byte units [24 bits] 512 x 64KB sectors, count = $32\text{MB}/256 = 131072$ value = count - 1 = $131072 - 1 = 131071 =$</p> <p>01FFFFh</p>			<p>Reserved = 1111b Supported Sector Type commands bit-field = 0010b Assuming 64KB sector type is assigned to sector type 2</p> <p>F2h</p>	<p><- Sector Region 0</p> <p>only 64KB erase commands supported in this region</p>	

6.5.8 Sector Map Parameter Table – Example 2

The memory device in the following example is 128Mbit density and has one sector map configuration. No configuration detection commands are needed because there is a single fixed sector map. The sector format is:

- Sixteen 4Kbyte sectors at the low address end (bottom) of the device address space, sixteen 4Kbyte sectors at the high address end (top) of the device address space, with all other sectors being 32Kbytes in size.

The Erase Types are defined as:

- Erase Type 1 = 4KB
- Erase Type 2 = 32KB
- Erase Type 3 = 64KB

All three Erase Types are supported in 4KB sector regions at the bottom and top of the address space. Only Erase Types 2 and 3 are supported in the region containing 32Kbyte sectors.

DWORD	Bits				Notes	
	31:24	23:16	15:8	7:0		
1	Reserved = FFh	Region Count = 3 Regions = 02h	Configuration ID = 00h	Reserved = 11111b Descriptor type = map = 1b Last map = 1b FFh	Configuration Map Header	Configuration Address Map Top and bottom 16x 4KB sectors, remainder uniform 32KB sector map
2	Region size as count-1 of 256 Byte units [24 bits] 16x 4KB sectors = 64KB, count = 64KB/256 = 256 value = count - 1 = 256 - 1 = 255 = 0000FFh			Reserved = 1111b Supported Sector Type commands bit-field = 0111b F7h	<- Sector Region 0 4KB, 32KB, and 64KB supported in this region	
3	Region size as count-1 of 256 Byte units [24 bits] 16MB -128KB region, count = 16646144 B/256 = 65024 value = count - 1 = 65024 - 1 = 65023 = 00FDFFh			Reserved = 1111b Supported Sector Type commands bit-field = 0110b F6h	<- Sector Region 1 32KB and 64KB erase commands supported in this region	
5	Region size as count-1 of 256 Byte units [24 bits] 16x 4KB sectors = 64KB, count = 64KB/256 = 256 value = count - 1 = 256 - 1 = 255 = 0000FFh			Reserved = 1111b Supported Sector Type commands bit-field = 0111b F7h	<- Sector Region 2 4KB, 32KB, and 64KB supported in this region	

6.6 Replay Protected Monotonic Counters (RPMC) Parameter Header and Table

The widely supported RPMC functionality has been adopted by JEDEC to control multiple nonvolatile monotonic counters integrated into a serial flash device. RPMC allows cryptographically secure host access to the (typically four) monotonic counters using packets that include a signature. The signature is generated using an HMAC-SHA256 process that guarantees the authenticity of the transferred packet. The details of RPMC functionality are described in a separate JEDEC specification.

This SFDP specification (starting with JESD216E) describes critical characteristics that allows a host to successfully communicate with an RPMC enabled device.

6.6.1 Replay Protected Monotonic Counters Parameter Header: 1st DWORD

Bits	Description
31:24	Parameter Table Length = 02h This field specifies how many DWORDs are in the parameter table. NOTE This field is 1's based. Therefore, 1 indicates 1 DWORD.
23:16	Parameter Table Major Revision Number = 01h This 8-bit field indicates the major revision number of the parameter table. The value in this field is 01h for this table newly defined by this JESD216E revision. NOTE The Major Revision of JEDEC defined parameter tables can only be modified by updates to this standard.
15:8	Parameter Table Minor Revision Number = 00h This 8-bit field indicates the minor revision number of the parameter table. The value in this field is 00h for this table newly defined by this JESD216E revision. NOTE The Minor Revision of the JEDEC owned parameter tables can only be modified by updates to this standard.
7:0	Parameter ID LSB = 03h The RPMC Parameter Table is assigned the ID (LSB) of 03h.

6.6.2 Replay Protected Monotonic Counters Parameter Header: 2nd DWORD

Bits	Description
31:24	Parameter ID MSB = FFh The RPMC Parameter Table is assigned the ID (MSB) of FFh.
23:0	Parameter Table Pointer (PTP) = <i>manufacturer specified</i> This address specifies the start of this header's Parameter Table in the SFDP structure. The address is in terms of bytes and must be DWORD-aligned.

6.6.3 Replay Protected Monotonic Counters Parameter Table, 1st DWORD

Bits	Description
31:28	RESERVED = Fh Value must be Fh.
27:24	Update Rate = <i>manufacturer specified</i> Rate of update = $5 * (2^{**}\text{Update Rate})$ seconds
23:16	RPMC Packet READ Command Opcode (OP2) = <i>manufacturer specified</i>
15:8	RPMC Packet WRITE Command Opcode (OP1) = <i>manufacturer specified</i>
7:4	Num Counters – 1 = <i>manufacturer specified</i> Number of supported counters minus one. Suggested value is 3 (4 counters supported).
3	RESERVED = 1b Value must be 1b.
2	Busy_Polling_Method = <i>manufacturer specified</i> 0b: Poll for OP1 BUSY using OP2 Extended Status[0]. No OP1 Suspend State support. 1b: Poll for OP1 BUSY using Read Status (05h). Suspend State is supported.
1	Monotonic Counter Size = 0b 0b: Monotonic Counter size is 32 bits 1b: Reserved
0	Flash Hardening = <i>manufacturer specified</i> 0b: Flash Hardening is supported 1b: Flash Hardening is not supported

6.6.4 Replay Protected Monotonic Counters Parameter Table, 2nd DWORD

Bits	Description
31:24	RESERVED = FFh Value must be FFh.
23:16	Write Counter Polling Long Delay = manufacturer specified Write + one HMAC Operation + Typical Subsector Erase Time Suggested usage: Allows controller to conserve power to delay polling if the short delay is not sufficient for completion of the write operation. Bit[23]: reserved Bits[22:21]: units (00b=1ms, 01b=16ms, 10b=128ms, 11b=1s) Bits[20:16]: <u>polling_long_delay_write_counter</u>
15:8	Write Counter Polling Short Delay = manufacturer specified Worst Case Write + one HMAC operation, No Erase Time Suggest usage: Allows controller to conserve power by delaying polling Bit [15]: reserved Bits[14:13]: units (00b=1us, 01b=16us, 10b=128us, 11b=1ms) Bits [12:8]: <u>polling short delay write counter</u>
7:0	Read Counter Polling Delay = manufacturer specified Typical case to calculate HMAC two times Suggested usage: Allows controller to conserve power by delaying polling for read monotonic counter or update HMAC register commands. Bit[7]: reserved Bits[6:5]: units (00b=1us, 01b=16us, 10b=128us, 11b=1ms) Bits[4:0]: <u>polling delay read counter</u>

6.7 JEDEC 4-byte Address Instruction Parameter Header and Table

Legacy SPI memory devices were limited to 128-Mbits (16-Mbytes) of address space by commands that provided only three bytes (24-bits) of address. Recent SPI memories that exceed 128-Mbits density provide various options for providing 4-bytes (32-bits) of address. One option is the use of commands that always provide 4-bytes of address. These commands in some cases have the same function as legacy 3-byte address commands but use a different instruction to indicate that 4-bytes of address follow the instruction. The 4-byte address instruction special function table indicates which 4-byte address command instructions are supported by the SPI memory. The table also provides the 4-byte address instructions for the four Erase Types defined in 8th DWORD of the Basic Flash Parameter Table. If a 4-byte address instruction is not supported for an Erase Type, the instruction for that type is shown in the table as FFh.

6.7.1 4-byte Address Instruction Parameter Header: 1st DWORD

Bits	Description
31:24	Parameter Table Length This field specifies how many DWORDs are in the Parameter table. NOTE This field is 1's based. Therefore, 1 indicates 1 DWORD.

23:16	<p>Parameter Table Major Revision Number This 8-bit field indicates the major revision number of the parameter table. The value in this field is 01h for this table defined by JESD216E revision (unchanged from JESD216D revision). NOTE The Major Revision of JEDEC defined parameter tables can only be modified by updates to this standard.</p>
15:8	<p>Parameter Table Minor Revision Number This 8-bit field indicates the minor revision number of the parameter table. The value in this field is 01h for this table defined by JESD216E revision (unchanged from JESD216D revision). NOTE The Minor Revision of the JEDEC owned parameter tables can only be modified by updates to this standard.</p>
7:0	<p>Parameter ID LSB 4-byte Address Instruction Table is assigned the ID LSB of 84h.</p>

6.7.2 4-byte Address Instruction Parameter Header: 2nd DWORD

Bits	Description
31:24	<p>Parameter ID MSB 4-byte Address Instruction Table is assigned the ID MSB of FFh.</p>
23:0	<p>Parameter Table Pointer (PTP) This address specifies the start of this header's Parameter Table in the SFDP structure. The address is in terms of bytes and must be DWORD-aligned.</p>

6.7.3 4-byte Address Instruction Table, 1st DWORD

Bit	Description
31:25	Reserved (Reserved bits did not have a defined value in previous versions of this spec, they are left unused)
24	Support for (1-8-8) Page Program Command, Instruction=8Eh 0: Not supported 1: Supported
23	Support for (1-1-8) Page Program Command, Instruction=84h 0: Not supported 1: Supported
22	Support for (1-8-8) DTR_READ Command, Instruction=FDh 0: Not supported 1: Supported
21	Support for (1-8-8) FAST_READ Command, Instruction=CCh 0: Not supported 1: Supported
20	Support for (1-1-8) FAST_READ Command, Instruction=7Ch 0: Not supported 1: Supported
19	Support for non-volatile individual sector lock write command, Instruction=E3h 0: Not supported 1: Supported
18	Support for non-volatile individual sector lock read command, Instruction=E2h 0: Not supported 1: Supported
17	Support for volatile individual sector lock Write command, Instruction=E1h 0: Not supported 1: Supported
16	Support for volatile individual sector lock Read command, Instruction=E0h 0: Not supported 1: Supported
15	Support for (1-4-4) DTR_Read Command, Instruction=EEh 0: Not supported 1: Supported
14	Support for (1-2-2) DTR_Read Command, Instruction=BEh 0: Not supported 1: Supported
13	Support for (1-1-1) DTR_Read Command, Instruction=0Eh 0: Not supported 1: Supported

6.7.3 4-byte Address Instruction Table, 1st DWORD (cont'd)

Bit	Description
12	Support for Erase Command – Type 4 size, Instruction lookup in next Dword 0: Not supported 1: Supported
11	Support for Erase Command – Type 3 size, Instruction lookup in next Dword 0: Not supported 1: Supported
10	Support for Erase Command – Type 2 size, Instruction lookup in next Dword 0: Not supported 1: Supported
9	Support for Erase Command – Type 1 size, Instruction lookup in next Dword 0: Not supported 1: Supported
8	Support for (1-4-4) Page Program Command, Instruction=3Eh 0: Not supported 1: Supported
7	Support for (1-1-4) Page Program Command, Instruction=34h 0: Not supported 1: Supported
6	Support for (1-1-1) Page Program Command, Instruction=12h 0: Not supported 1: Supported
5	Support for (1-4-4) FAST_READ Command, Instruction=EC 0: Not supported 1: Supported
4	Support for (1-1-4) FAST_READ Command, Instruction=6Ch 0: Not supported 1: Supported
3	Support for (1-2-2) FAST_READ Command, Instruction=BC 0: Not supported 1: Supported
2	Support for (1-1-2) FAST_READ Command, Instruction=3C 0: Not supported 1: Supported
1	Support for (1-1-1) FAST_READ Command, Instruction=0C 0: Not supported 1: Supported
0	Support for (1-1-1) READ Command, Instruction=13h 0: Not supported 1: Supported

6.7.4 4-byte Address Instruction Table, 2nd DWORD

NOTE (informative) Industry common usage is:

21h	4 kbyte erase
5Ch	32 kbyte erase
DCh	64 kbyte erase
DCh	256 kbyte erase

Bit	Description
31:24	Instruction for Erase Type 4 Erase Type is defined in 9 th DWORD of the Basic Flash Parameter Table
23:16	Instruction for Erase Type 3 Erase Type is defined in 9 th DWORD of the Basic Flash Parameter Table
15:8	Instruction for Erase Type 2 Erase Type is defined in 8 th DWORD of the Basic Flash Parameter Table
7:0	Instruction for Erase Type 1 Erase Type is defined in 8 th DWORD of the Basic Flash Parameter Table

6.8 JEDEC eXpanded Serial Peripheral Interface (xSPI) Profile 1.0 Parameter Header and Table

See JESD251, eXpanded Serial Peripheral Interface (xSPI) for Non-Volatile Memory Devices, Version 1 for details about this interface. This interface supports 2 profiles. Profile 1.0 is covered in 6.8, Profile 2.0 is covered in 6.9. A host controller may support both profiles, target devices will typically support only one of the profiles.

6.8.1 JEDEC xSPI (Profile 1.0) Parameter Header: 1st DWORD

Bits	Description
31:24	Parameter Table Length This field specifies how many DWORDs are in the Parameter table. NOTE This field is 1's based. Therefore, 1 indicates 1 DWORD.
23:16	Parameter Table Major Revision Number This 8-bit field indicates the major revision number of the parameter table. The value in this field is 01h for this table defined by JESD216E revision (unchanged from JESD216D revision). NOTE The Major Revision of JEDEC defined parameter tables can only be modified by updates to this standard.
15:8	Parameter Table Minor Revision Number This 8-bit field indicates the minor revision number of the parameter table. The value in this field is 00h for this table defined by JESD216E revision (unchanged from JESD216D revision). NOTE The Minor Revision of the JEDEC owned parameter tables can only be modified by updates to this standard.
7:0	Parameter ID LSB The eXpanded Serial Peripheral Interface (Profile 1) is assigned the ID LSB of 05h.

6.8.2 JEDEC xSPI (Profile 1.0) Parameter Header: 2nd DWORD

Bits	Description
31:24	Parameter ID MSB The eXpanded Serial Peripheral Interface is assigned the ID MSB of FFh.
23:0	Parameter Table Pointer (PTP) This address specifies the start of this header's Parameter Table in the SFDP structure. The address is in terms of bytes and must be DWORD-aligned.

6.8.3 JEDEC xSPI (Profile 1.0) Parameter Table: 1st DWORD - Command Codes used in 8D-8D-8D protocol mode

The commands listed here are those that have more than one option for Command Code listed in “Table 6-2 Profile 1.0 commands used in 8D-8D-8D protocol mode (required commands)” or in “Table 6 3 Profile 1.0 commands used in 8D-8D-8D protocol mode (optional commands)” in the xSPI standard.

The opcodes for the Erase commands are provided in 6.4.11 to 6.4.13, and are therefore not repeated here. For the optional commands that are not supported as indicated in 3rd DWORD below, the parameter fields in this DWORD are not applicable.

Bits	Description
31	SFDP Command in 8D-8D-8D mode – Address Bytes See Figure 5 0b: 32-bit address (For most devices, SFDP is still limited to a 24-bit address space. This means MSB is 0, and the 24 bit address is in the last 3 bytes) 1b: 24-bit address, left adjusted (24 bit address is in the first 3 bytes, LSB is 0)
30	SFDP Command in 8D-8D-8D mode – Dummy Cycles See Figure 5 0b: 8 1b: 20
29	Number of Additional Modifier Bytes Used for Read Status Register command 1: 4 bytes 0: 0 bytes
28	Initial Latency (CK cycles) for Read Status Register command 1: 8 CK cycles 0: 4 CK cycles
27	Number of Additional Modifier Bytes Used for Read Register command 1: 4 bytes 0: 1 byte
26	Initial Latency (CK cycles) for Read Volatile Register command 1: 8 CK cycles 0: 4 CK cycles
25	Initial Latency (CK cycles) for Read Non-Volatile Register command 1: 8 CK cycles 0: 4 CK cycles
24	Number of Additional Modifier Bytes Used for Write Status-Cfg Register command 1: 4 bytes 0: 0 bytes
23	Number of Additional Modifier Bytes Used for Write Register command 1: 4 bytes 0: 1 byte
22	Number of Data Bytes Used for Write Register command 1: 2 bytes 0: 1 byte
21:16	Reserved. Leave as “0”. (This allows new features to be added to these bits in the future.)
15:8	Read Fast command
7:0	Read Fast Wrapped command 00h means not supported

6.8.4 JEDEC xSPI (Profile 1.0) Parameter Table: 2nd DWORD - Command Codes used in 8D-8D-8D protocol mode

Bits	Description
31-24	Read Volatile Register command
23:16	Read NV Register command
15:8	Write Volatile Register command
7:0	Write NV Register command

6.8.5 JEDEC xSPI (Profile 1.0) Parameter Table: 3rd DWORD - Memory Commands Supported in 8D-8D-8D protocol mode

This is the list of *optional* commands in 8D-8D-8D protocol mode. The command code for each of these is found in and Table 6-3 in the xSPI standard. For the commands that have more than one option for Command Code listed in the xSPI standard, the command code for each of these is found in the JEDEC xSPI (Profile 1.0) Parameter Table: 1st to 2nd DWORD above. Table 6-2 in the xSPI standard lists the required commands for this profile. The required commands are not listed here.

Bits	Description
31	Read SFDP 8D-8D-8D 1: Command Supported 0: Command Not Supported
30	Read Fast Wrapped 1: Command Supported 0: Command Not Supported
29	Setup Read Wrap 1: Command Supported 0: Command Not Supported
28	Erase 4Kbytes 1: Command Supported 0: Command Not Supported
27	Erase 32Kbytes 1: Command Supported 0: Command Not Supported
26	Erase Chip 1: Command Supported 0: Command Not Supported
25	Read Configuration Register 1: Command Supported 0: Command Not Supported
24	Read Flag Status Register 1: Command Supported 0: Command Not Supported
23	Read Register 1: Command Supported 0: Command Not Supported
22	Read Volatile Register 1: Command Supported 0: Command Not Supported

21	Read NV Register 1: Command Supported 0: Command Not Supported
20	Write Status-Configuration Register 1: Command Supported 0: Command Not Supported
19	Clear Flag Status Reg 1: Command Supported 0: Command Not Supported
18	Write Register 1: Command Supported 0: Command Not Supported
17	Write Volatile Register 1: Command Supported 0: Command Not Supported
16	Write NV Register 1: Command Supported 0: Command Not Supported
15	Enter Deep Power Down 1: Command Supported 0: Command Not Supported
14	Exit Deep Power Down 1: Command Supported 0: Command Not Supported
13	Soft Reset 1: Command Supported 0: Command Not Supported
12	Reset Enable 1: Command Supported 0: Command Not Supported
11	Soft Reset and Enter default protocol mode. 1: Command Supported 0: Command Not Supported
10	Enter default protocol mode 1: Command Supported 0: Command Not Supported
9-0	Reserved. Leave as "0". (This allows new features to be added to these bits in the future.)

6.8.6 JEDEC xSPI (Profile 1.0) Parameter Table: 4th DWORD - Dummy cycles used for various frequencies

Bits	Description
31-12	Reserved. Leave as “0”. (This allows new features to be added to these bits in the future.)
11:7	200MHz operation: number of dummy cycles required A value of 0 means this frequency is not supported
6:2	200MHz operation: configuration bit pattern to set this number of dummy cycles
1:0	Reserved. Leave as “0”. (This allows new features to be added to these bits in the future.)

6.8.7 JEDEC xSPI (Profile 1.0) Parameter Table: 5th DWORD - Dummy cycles used for various frequencies

Bits	Description
31-27	166MHz operation: number of dummy cycles required A value of 0 means this frequency is not supported
26:22	166MHz operation: configuration bit pattern to set this number of dummy cycles
21:17	133MHz operation: number of dummy cycles required A value of 0 means this frequency is not supported
16:12	133MHz operation: configuration bit pattern to set this number of dummy cycles
11:7	100MHz operation: number of dummy cycles required A value of 0 means this frequency is not supported
6:2	100MHz operation: configuration bit pattern to set this number of dummy cycles
1:0	Reserved. Leave as “0”. (This allows new features to be added to these bits in the future.)

6.9 JEDEC eXpanded Serial Peripheral Interface (xSPI) - Profile 2.0 Parameter Header and Table

See JESD251, eXpanded Serial Peripheral Interface (xSPI) for Non Volatile Memory Devices, Version 1 for details about this interface. This interface supports 2 profiles. Profile 1.0 is covered in 6.8, Profile 2.0 is covered in 6.9. A host controller may support both profiles, target devices will typically support only one of the profiles.

6.9.1 JEDEC xSPI (Profile 2.0) Parameter Header: 1st DWORD

Bits	Description
31:24	<p>Parameter Table Length This field specifies how many DWORDs are in the Parameter table.</p> <p>NOTE This field is 1's based. Therefore, 1 indicates 1 DWORD.</p>
23:16	<p>Parameter Table Major Revision Number¹ This 8-bit field indicates the major revision number of the associated parameter table. The value in this field is 01h for this table defined by JESD216E revision (unchanged from JESD216D revision).</p> <p>NOTE Major Revision starts at 01h. The Major Revision of JEDEC defined parameter tables can only be modified by updates to this standard.</p>
15:8	<p>Parameter Table Minor Revision Number¹ This 8-bit field indicates the minor revision number of the associated parameter table. The value in this field is 00h for this table defined by JESD216E revision (unchanged from JESD216D revision).</p> <p>NOTE Minor Revision starts at 00h. The Minor Revision of the JEDEC owned parameter tables can only be modified by updates to this standard.</p>
7:0	<p>Parameter ID LSB (0x06) The eXpanded Serial Peripheral Interface (Profile 2) is assigned the ID LSB of 06h.</p>

NOTE See "Major vs. Minor Revisions" in 6.2

6.9.2 JEDEC xSPI (Profile 2.0) Parameter Header: 2nd DWORD

Bits	Description
31:24	<p>Parameter ID MSB (0xFF) Refer to Definition of Parameter ID Field below.</p>
23:0	<p>Parameter Table Pointer (PTP) This address specifies the start of this header's Parameter Table in the SFDP structure. This is a byte address and must be DWORD-aligned.</p>

6.9.3 JEDEC xSPI (Profile 2.0) Parameter Table: 1st DWORD - Command Codes used in 8D-8D-8D Profile 2.0 protocol mode

Bits	Description
31	xSPI Support 1: Device implements 8D-8D-8D Profile 2.0 protocol mode as defined in JEDEC xSPI spec 0: Not Supported
30	Read Register Wrapped 1: Command Supported 0: Command Not Supported
29	Read Register Linear 1: Command Supported 0: Command Not Supported
28	Read Memory Wrapped 1: Command Supported 0: Command Not Supported
27	Read Memory Linear 1: Command Supported 0: Command Not Supported
26	Write Register Wrapped 1: Command Supported 0: Command Not Supported
25	Write Register Linear 1: Command Supported 0: Command Not Supported
24	Memory Wrapped 1: Command Supported 0: Command Not Supported
23	Write Memory Wrapped 1: Command Supported 0: Command Not Supported
22	WREN1 (Write Enable 1) 1: Command Supported 0: Command Not Supported
21	WREN2 (Write Enable 2) 1: Command Supported 0: Command Not Supported
20	SREN (Status Register Enable) 1: Command Supported 0: Command Not Supported
19	Status Register Read 1: Command Supported 0: Command Not Supported
18	Status Register Clear 1: Command Supported 0: Command Not Supported
17	Configuration Register Read 1: Command Supported 0: Command Not Supported
16	Configuration Register Load 1: Command Supported 0: Command Not Supported

15	Deep Power Down 1: Command Supported 0: Command Not Supported
14	Word Program 1: Command Supported 0: Command Not Supported
13	Sector Erase 1: Command Supported 0: Command Not Supported
12	Chip Erase 1: Command Supported 0: Command Not Supported
11	Erase Suspend 1: Command Supported 0: Command Not Supported
10	Erase Resume 1: Command Supported 0: Command Not Supported
9	Write to Buffer 1: Command Supported 0: Command Not Supported
8	Program Write to Buffer 1: Command Supported 0: Command Not Supported
7	Program Suspend 1: Command Supported 0: Command Not Supported
6	Program Resume 1: Command Supported 0: Command Not Supported
5	Enter SPI (1S-1S-1S) 1: Command Supported 0: Command Not Supported
4:0	Reserved. Leave as “0”. (This allows new features to be added to these bits in the future.)

6.9.4 JEDEC xSPI (Profile 2.0) Parameter Table: 2nd DWORD - Dummy cycles used for various frequencies

Bits	Description
31-12	Reserved. Leave as “0”. (This allows new features to be added to these bits in the future.)
11:7	200MHz operation: number of dummy cycles required A value of 0 means this frequency is not supported
6:2	200MHz operation: configuration bit pattern to set this number of dummy cycles
1:0	Reserved. Leave as “0”. (This allows new features to be added to these bits in the future.)

6.9.5 JEDEC xSPI (Profile 2.0) Parameter Table: 3rd DWORD - Dummy cycles used for various frequencies

Bits	Description
31:27	166MHz operation: number of dummy cycles required A value of 0 means this frequency is not supported
26:22	166MHz operation: configuration bit pattern to set this number of dummy cycles
21:17	133MHz operation: number of dummy cycles required A value of 0 means this frequency is not supported
16:12	133MHz operation: configuration bit pattern to set this number of dummy cycles
11:7	100MHz operation: number of dummy cycles required A value of 0 means this frequency is not supported
6:2	100MHz operation: configuration bit pattern to set this number of dummy cycles
1:0	Reserved. Leave as “0”. (This allows new features to be added to these bits in the future.)

6.10 Status, Control and Configuration Register Map for SPI Memory Devices

SPI memory devices from different manufacturers have widely different configurations for Status, Control and Configuration registers. The Status, Control and Configuration Register Map (SCCR Map for short) defines a common nomenclature for the most common register bits and their functions, and describes how the individual bits may be accessed for a specific device.

This section covers the SCCR Map for Single, Dual, Quad and xSPI Profile 1.0 Octal memory devices. xSPI Profile 2.0 Octal memory devices are covered in 6.11.

The purpose of the SCCR Map is to provide a host controller with a minimum amount of information to be able to boot a system and load necessary code for the system to run. It is to be expected that the code loaded from the memory device will contain the necessary information required to achieve optimum performance from the device.

Register bits may be accessed by a command specifying an address and a register value, or by a direct command accessing a specific register or bit directly. (05h, “Read Status Register”, is an example of a direct command.) For each bit, the SCCR Map defines which command (if any) is used to write the bit, which command is used to read the bit, which position the bit has in the register and at which address (if any) the register is located. (An address of FFh indicates that no address is used and the commands are direct commands.)

The register address is defined as a 32-bit address in the SCCR Map. For devices using less than 32 bits for Generic Addressable Read/Write Status/Control register commands, the uppermost bits should be ignored. (Sending a 32-bit address to a device expecting an 8-bit address will not produce the desired result.) The actual number of address bytes and the number of dummy bytes/dummy cycles used for Generic Addressable Read/Write Status/Control register commands by the device is provided in 6.10.5.

To avoid the need to provide a full 32-bit address for each bit, the addressing scheme in this table takes into account that every device uses a narrow range of addresses for the SCCR. The address is therefore defined as a 32-bit offset address pointer, which indicates the start of the address block, and an 8-bit local address, which indicates the position of each register within the block.

6.9 Status, Control and Configuration Register Map for SPI Memory Devices (cont'd)

The physical address of a register is found by adding the 32-bit offset address pointer and the 8-bit local address. Separate 32-bit offset address pointers are provided for volatile and non-volatile address blocks.

The 8-bit local address can either be added to the last byte of the 32-byte address, creating an address of the format xxxx-xxxx xxxx-xxxx xxxx-xxxx AAAA-AAAA.

The 8-bit local address can be added to Byte 1 of the 32-bit address, creating an address of the format xxxx-xxxx xxxx-xxxx AAAA-AAAA xxxx-xxxx.

Which of the two options is used is described in the parameter table for each bit.

In the SCCR Map, each bit is defined separately. In an actual device, multiple of these bits will be combined into one physical register (e.g., the Status Register). The physical registers may also include additional bits that are not part of the current SCCR Map. **It is therefore important that the host controller reads the current value of the register and only changes the intended bits before writing the value back to the register to ensure that other functions are not affected.** (“Read-Modify-Write” operations may be used if available.)

Even though the Status, Control and Configuration Register Map was initially developed as part of the xSPI protocol spec, this information can also be added for other devices.

Registers may be status, control or configuration registers.

These register definitions describe the bit locations after the device is powered up. For devices where status control register bits change to other address locations after a mode change, the host controller software (loaded from the device at boot) will have to deal with that.

6.10.1 SCCR Map for SPI Memory Devices Parameter Header: 1st DWORD

Bits	Description
31:24	Parameter Table Length This field specifies how many DWORDs are in the Parameter table. NOTE This field is 1's based. Therefore, 1 indicates 1 DWORD.
23:16	Parameter Table Major Revision Number This 8-bit field indicates the major revision number of the parameter table. The value in this field is 01h for this table defined by JESD216E revision (unchanged from JESD216D revision). NOTE The Major Revision of JEDEC defined parameter tables can only be modified by updates to this standard.
15:8	Parameter Table Minor Revision Number This 8-bit field indicates the minor revision number of the Status, Control and Configuration Register Map Parameter Table. The value in this field is 01h for this table defined by JESD216D. NOTE The Minor Revision of the JEDEC owned parameter tables can only be modified by updates to this standard.
7:0	Parameter ID LSB The Status, Control and Configuration Register Map is assigned the ID LSB of 87h.

6.10.2 SCCR Map for SPI Memory Devices Parameter Header: 2nd DWORD

Bits	Description
31:24	Parameter ID MSB The Status, Control and Configuration Register Map is assigned the ID MSB of FFh.
23:0	Parameter Table Pointer (PTP) This address specifies the start of this header's Parameter Table in the SFDP structure. The address is in terms of bytes and must be DWORD-aligned.

6.10.3 SCCR Map for SPI Memory Devices Parameter Table: 1st DWORD – Volatile registers address offset

Bits	Description
31:0	Address offset for volatile registers

6.10.4 SCCR Map for SPI Memory Devices Parameter Table: 2nd DWORD – Non-Volatile registers address offset

Bits	Description
31:0	Address offset for non-volatile registers

6.10.5 SCCR Map for SPI Memory Devices Parameter Table: 3rd DWORD – Generic Addressable Read/Write Status/Control register commands for volatile registers

Bits	Description
31	Generic Addressable Read Status/Control register command for volatile registers supported for some (or all) registers 0: Not supported for any register 1: Supported for some (or all) registers
30	Generic Addressable Write Status/Control register command for volatile registers supported for some (or all) registers 0: Not supported for any register 1: Supported for some (or all) registers
29:28	Number of address bytes used for Generic Addressable Read/Write Status/Control register commands for volatile registers: (The number of address bytes used for accessing registers may be different from the number of address bytes used for accessing the memory array.) 00: 1 byte (8-bit) 01: 2 bytes (16-bit) 10: 3 bytes (24-bit) 11: 4 bytes (32-bit)
27:26	Number of dummy bytes used for Generic Addressable Read Status/Control register command for volatile registers in (1S-1S-1S) mode: 00: 0 bytes (no dummy cycles required) 01: 1 byte (8-bit) 10: Use the number of bits as defined in bits 3:0 in this DWORD 11: Command not supported in this mode
25:22	Number of dummy cycles used for Generic Addressable Read Status/Control register command for volatile registers in (2S-2S-2S) mode 0000-1110:[0-14 cycles] 1111: Command not supported in this mode
21:18	Number of dummy cycles used for Generic Addressable Read Status/Control register command for volatile registers in (4S-4S-4S) mode 0000-1110:[0-14 cycles] 1111: Command not supported in this mode
17:14	Number of dummy cycles used for Generic Addressable Read Status/Control register command for volatile registers in (4S-4D-4D) mode 0000-1110:[0-14 cycles] 1111: Command not supported in this mode
13:10	Number of dummy cycles used for Generic Addressable Read Status/Control register command for volatile registers in (8S-8S-8S) mode 0000-1110:[0-14 cycles] 1111: Command not supported in this mode
9:6	Number of dummy cycles used for Generic Addressable Read Status/Control register command for volatile registers in (8D-8D-8D) mode 0000-1110:[0-14 cycles] 1111: Command not supported in this mode
5:4	Reserved. Leave as “0”. (This allows new features to be added to these bits in the future.)
3:0	Number of dummy cycles used for Generic Addressable Read Status/Control register command for volatile registers in (1S-1S-1S) mode – If bits 27:26 above equal 10: 0000-1110: [0-14 cycles] 1111: Command not supported in this mode

6.10.6 SCCR Map for SPI Memory Devices Parameter Table: 4th DWORD – Generic Addressable Read/Write Status/Control register commands for non-volatile registers

Bits	Description
31	Generic Addressable Read Status/Control register command for non-volatile registers supported for some (or all) registers 0: Not supported for any register 1: Supported for some (or all) registers
30	Generic Addressable Write Status/Control register command for non-volatile registers supported for some (or all) registers 0: Not supported for any register 1: Supported for some (or all) registers
29:28	Number of address bytes used for Generic Addressable Read/Write Status/Control register commands for non-volatile registers: (The number of address bytes used for accessing registers may be different from the number of address bytes used for accessing the memory array.) 00: 1 byte (8-bit) 01: 2 bytes (16-bit) 10: 3 bytes (24-bit) 11: 4 bytes (32-bit)
27:26	Number of dummy bytes used for Generic Addressable Read Status/Control register command for non-volatile registers in (1S-1S-1S) mode: 00: 0 bytes (no dummy cycles required) 01: 1 byte (8-bit) 10: Use the number of bits as defined in bits 3:0 in this DWORD 11: Command not supported in this mode
25:22	Number of dummy cycles used for Generic Addressable Read Status/Control register command in (2S-2S-2S) mode 0000-1110:[0-14 cycles] 1111: Command not supported in this mode
21:18	Number of dummy cycles used for Generic Addressable Read Status/Control register command for non-volatile registers in (4S-4S-4S) mode 0000-1110:[0-14 cycles] 1111: Command not supported in this mode
17:14	Number of dummy cycles used for Generic Addressable Read Status/Control register command for non-volatile registers in (4S-4D-4D) mode 0000-1110:[0-14 cycles] 1111: Command not supported in this mode
13:10	Number of dummy cycles used for Generic Addressable Read Status/Control register command for non-volatile registers in (8S-8S-8S) mode 0000-1110:[0-14 cycles] 1111: Command not supported in this mode
9:6	Number of dummy cycles used for Generic Addressable Read Status/Control register command for non-volatile registers in (8D-8D-8D) mode 0000-1110:[0-14 cycles] 1111: Command not supported in this mode
5:4	Reserved. Leave as “0”. (This allows new features to be added to these bits in the future.)
3:0	Number of dummy cycles used for Generic Addressable Read Status/Control register command for non-volatile registers in (1S-1S-1S) mode – If bits 27:26 above equal 10: 0000-1110: [0-14 cycles] 1111: Command not supported in this mode

6.10.7 SCCR Map for SPI Memory Devices Parameter Table: 5th DWORD – WIP (Required for xSPI)

Bits	Description
31	Write In Progress (WIP) bit available: 0: Not supported 1: Supported
30	Write In Progress (WIP) polarity: 0: Positive (WIP=1 means write is in progress) 1: Inverted (WIP=0 means write is in progress)
29	Reserved. Leave as “0”. (This allows new features to be added to these bits in the future.)
28	Bit is accessed by commands using address 0: Bit is accessed by direct commands (Commands do not use address) 1: Bit is accessed by commands using address
27	0: Local address for WIP bit is found in last byte of the address: (Byte 0 of 32-bit address space): xxxx-xxxx xxxx-xxxx xxxx-xxxx AAAA-AAAA (Byte 0 of 24-bit address space): xxxx-xxxx xxxx-xxxx AAAA-AAAA (Byte 0 of 8-bit address space): AAAA-AAAA 1: Local address for WIP bit is found in Byte 1 of 32-bit address: xxxx-xxxx xxxx-xxxx AAAA-AAAA xxxx-xxxx (This option may also be used for 24-bit addressing, but is not applicable for devices using 8-bit addressing)
26-24	Bit location of WIP bit in register
23-16	If Bit 28 is 1: Address of register where bit is located Local address AAAA-AAAA If Bit 28 is 0: Modes supported and dummy cycles used for direct command Bit 23: 1: 8D-8D-8D mode supported, using the # of dummy cycles shown in bits 19-16 0: 8D-8D-8D mode not supported, using the # of dummy cycles shown in bits 19-16 Bit 22: 1: 8S-8S-8S mode supported, using the # of dummy cycles shown in bits 19-16 0: 8S-8S-8S mode not supported, using the # of dummy cycles shown in bits 19-16 Bit 21: 1: 4S-4D-4D mode supported, using the # of dummy cycles shown in bits 19-16 0: 4S-4D-4D mode not supported, using the # of dummy cycles shown in bits 19-16 Bit 20: 1: 4S-4S-4S mode supported, using the # of dummy cycles shown in bits 19-16 0: 4S-4S-4S mode not supported, using the # of dummy cycles shown in bits 19-16 Bits 19-16: Number of dummy cycles (0-15) used NOTE 1-1-1 mode, if supported by the device, will be supporting this command without using dummy cycles. NOTE Modes indicated as not supported may still be supported by the device, but not using the same number of dummy cycles as listed here. NOTE Other modes may also be supported by the device.
15-8	Command used for read access 00h means not supported
7-0	Command used for write access 00h means not supported (bit is read only)

6.10.8 SCCR Map for SPI Memory Devices Parameter Table: 6th DWORD – WEL

Bits	Description
31	Write Enable (WEL) bit available: 0: Not supported 1: Supported
30	Write Enable (WEL) polarity: 0: Positive (WEL =1 means write is enabled) 1: Inverted (WEL =0 means write is enabled)
29	Write access of WEL bit 0: Write command uses a bit field to identify bit location of WEL bit in register 1: Write command is a direct operation to set WEL bit
28	Bit is accessed by commands using address 0: Bit is accessed by direct commands (Commands do not use address) 1: Bit is accessed by commands using address
27	0: Local address for WEL bit is found in last byte of the address: (Byte 0 of 32-bit address space): xxxx-xxxx xxxx-xxxx xxxx-xxxx AAAA-AAAA (Byte 0 of 24-bit address space): xxxx-xxxx xxxx-xxxx AAAA-AAAA (Byte 0 of 8-bit address space): AAAA-AAAA 1: Local address for WEL bit is found in Byte 1 of 32-bit address: xxxx-xxxx xxxx-xxxx AAAA-AAAA xxxx-xxxx (This option may also be used for 24-bit addressing, but is not applicable for devices using 8-bit addressing)
26-24	Bit location of WEL bit in register
23-16	If Bit 28 is 1: Address of register where bit is located Local address AAAA-AAAA If Bit 28 is 0: Modes supported and dummy cycles used for direct command Bit 23: 1: 8D-8D-8D mode supported, using the # of dummy cycles shown in bits 19-16 0: 8D-8D-8D mode not supported, using the # of dummy cycles shown in bits 19-16 Bit 22: 1: 8S-8S-8S mode supported, using the # of dummy cycles shown in bits 19-16 0: 8S-8S-8S mode not supported, using the # of dummy cycles shown in bits 19-16 Bit 21: 1: 4S-4D-4D mode supported, using the # of dummy cycles shown in bits 19-16 0: 4S-4D-4D mode not supported, using the # of dummy cycles shown in bits 19-16 Bit 20: 1: 4S-4S-4S mode supported, using the # of dummy cycles shown in bits 19-16 0: 4S-4S-4S mode not supported, using the # of dummy cycles shown in bits 19-16 Bits 19-16: Number of dummy cycles (0-15) used NOTE 1-1-1 mode, if supported by the device, will be supporting this command without using dummy cycles. NOTE Modes indicated as not supported may still be supported by the device, but not using the same number of dummy cycles as listed here. NOTE Other modes may also be supported by the device.
15-8	Command used for read access 00h means not supported
7-0	Command used for write access 00h means not supported

6.10.9 SCCR Map for SPI Memory Devices Parameter Table: 7th DWORD – Program Error

Bits	Description
31	Program Error bit available: 0: Not supported 1: Supported
30	Program Error bit polarity: 0: Positive (Program Error = 0 means no error, Program Error = 1 means last Program operation created an error) 1: Inverted (Program Error = 1 means no error, Program Error = 0 means last Program operation created an error)
29	Sharing 0: Not shared: The device has separate bits for Program Error and Erase Error 1: Shared: The same bit is used for both Program Error and Erase Error
28	Bit is accessed by commands using address 0: Bit is accessed by direct commands (Commands do not use address) 1: Bit is accessed by commands using address
27	0: Local address for Program Error bit is found in last byte of the address: (Byte 0 of 32-bit address space): xxxx-xxxx xxxx-xxxx xxxx-xxxx AAAA-AAAA (Byte 0 of 24-bit address space): xxxx-xxxx xxxx-xxxx AAAA-AAAA (Byte 0 of 8-bit address space): AAAA-AAAA 1: Local address for Program Error bit is found in Byte 1 of 32-bit address: xxxx-xxxx xxxx-xxxx AAAA-AAAA xxxx-xxxx (This option may also be used for 24-bit addressing, but is not applicable for devices using 8-bit addressing)
26-24	Bit location of Program Error bit in register
23-16	If Bit 28 is 1: Address of register where bit is located Local address AAAA-AAAA If Bit 28 is 0: Modes supported and dummy cycles used for direct command Bit 23: 1: 8D-8D-8D mode supported, using the # of dummy cycles shown in bits 19-16 0: 8D-8D-8D mode not supported, using the # of dummy cycles shown in bits 19-16 Bit 22: 1: 8S-8S-8S mode supported, using the # of dummy cycles shown in bits 19-16 0: 8S-8S-8S mode not supported, using the # of dummy cycles shown in bits 19-16 Bit 21: 1: 4S-4D-4D mode supported, using the # of dummy cycles shown in bits 19-16 0: 4S-4D-4D mode not supported, using the # of dummy cycles shown in bits 19-16 Bit 20: 1: 4S-4S-4S mode supported, using the # of dummy cycles shown in bits 19-16 0: 4S-4S-4S mode not supported, using the # of dummy cycles shown in bits 19-16 Bits 19-16: Number of dummy cycles (0-15) used NOTE 1-1-1 mode, if supported by the device, will be supporting this command without using dummy cycles. NOTE Modes indicated as not supported may still be supported by the device, but not using the same number of dummy cycles as listed here. NOTE Other modes may also be supported by the device.
15-8	Command used for read access 00h means not supported
7-0	Command used for write access 00h means not supported (bit is read only)

6.10.10 SCCR Map for SPI Memory Devices Parameter Table: 8th DWORD – Erase Error

Bits	Description
31	Erase Error bit available: 0: Not supported 1: Supported
30	Erase Error bit polarity: 0: Positive (Erase Error = 0 means no error, Erase Error = 1 means last Erase operation created an error) 1: Inverted (Erase Error = 1 means no error, Erase Error = 0 means last Erase operation created an error)
29	Sharing 0: Not shared: The device has separate bits for Program Error and Erase Error 1: Shared: The same bit is used for both Program Error and Erase Error
28	Bit is accessed by commands using address 0: Bit is accessed by direct commands (Commands do not use address) 1: Bit is accessed by commands using address
27	0: Local address for Erase Error bit is found in last byte of the address: (Byte 0 of 32-bit address space): xxxx-xxxx xxxx-xxxx xxxx-xxxx AAAA-AAAA (Byte 0 of 24-bit address space): xxxx-xxxx xxxx-xxxx AAAA-AAAA (Byte 0 of 8-bit address space): AAAA-AAAA 1: Local address for Erase Error bit is found in Byte 1 of 32-bit address: xxxx-xxxx xxxx-xxxx AAAA-AAAA xxxx-xxxx (This option may also be used for 24-bit addressing, but is not applicable for devices using 8-bit addressing)
26-24	Bit location of Erase Error bit in register
23-16	If Bit 28 is 1: Address of register where bit is located Local address AAAA-AAAA If Bit 28 is 0: Modes supported and dummy cycles used for direct command Bit 23: 1: 8D-8D-8D mode supported, using the # of dummy cycles shown in bits 19-16 0: 8D-8D-8D mode not supported, using the # of dummy cycles shown in bits 19-16 Bit 22: 1: 8S-8S-8S mode supported, using the # of dummy cycles shown in bits 19-16 0: 8S-8S-8S mode not supported, using the # of dummy cycles shown in bits 19-16 Bit 21: 1: 4S-4D-4D mode supported, using the # of dummy cycles shown in bits 19-16 0: 4S-4D-4D mode not supported, using the # of dummy cycles shown in bits 19-16 Bit 20: 1: 4S-4S-4S mode supported, using the # of dummy cycles shown in bits 19-16 0: 4S-4S-4S mode not supported, using the # of dummy cycles shown in bits 19-16 Bits 19-16: Number of dummy cycles (0-15) used NOTE 1-1-1 mode, if supported by the device, will be supporting this command without using dummy cycles. NOTE Modes indicated as not supported may still be supported by the device, but not using the same number of dummy cycles as listed here. NOTE Other modes may also be supported by the device.
15-8	Command used for read access 00h means not supported
7-0	Command used for write access 00h means not supported (bit is read only)

6.10.11 SCCR Map for SPI Memory Devices Parameter Table: 9th DWORD – Variable Dummy Cycle Settings – Volatile Register

Bits	Description
31	<p>Variable number of dummy cycles supported 0: Not supported, or supported in a way that cannot be described correctly by this parameter table 1: Supported</p>
30-29	<p>Number of physical bits used to set wait states 00: 2 bits 01: 3 bits 10: 4 bits 11: 5 bits</p>
28	<p>Bits are accessed by commands using address 0: Bits are accessed by direct commands (Commands do not use address) 1: Bits are accessed by commands using address</p>
27	<p>0: Local address for Variable Dummy Cycle Settings bits is found in last byte of the address: (Byte 0 of 32-bit address space): xxxx-xxxx xxxx-xxxx xxxx-xxxx AAAA-AAAA (Byte 0 of 24-bit address space): xxxx-xxxx xxxx-xxxx AAAA-AAAA (Byte 0 of 8-bit address space): AAAA-AAAA 1: Local address for Variable Dummy Cycle Settings bits is found in Byte 1 of 32-bit address: xxxx-xxxx xxxx-xxxx AAAA-AAAA xxxx-xxxx (This option may also be used for 24-bit addressing, but is not applicable for devices using 8-bit addressing)</p>
26-24	<p>Bit location of LSb of physical bits in register (Requirements: The physical bits used in a device are in the same (one) register, the bits form a continuous field and the bits are in order. If these requirements are not met, bit 31 above has to be set to 0.)</p>
23-16	<p>If Bit 28 is 1: Address of registers where bits are located Local address AAAA-AAAA If Bit 28 is 0: Modes supported and dummy cycles used for direct command Bit 23: 1: 8D-8D-8D mode supported, using the # of dummy cycles shown in bits 19-16 0: 8D-8D-8D mode not supported, using the # of dummy cycles shown in bits 19-16 Bit 22: 1: 8S-8S-8S mode supported, using the # of dummy cycles shown in bits 19-16 0: 8S-8S-8S mode not supported, using the # of dummy cycles shown in bits 19-16 Bit 21: 1: 4S-4D-4D mode supported, using the # of dummy cycles shown in bits 19-16 0: 4S-4D-4D mode not supported, using the # of dummy cycles shown in bits 19-16 Bit 20: 1: 4S-4S-4S mode supported, using the # of dummy cycles shown in bits 19-16 0: 4S-4S-4S mode not supported, using the # of dummy cycles shown in bits 19-16 Bits 19-16: Number of dummy cycles (0-15) used NOTE 1-1-1 mode, if supported by the device, will be supporting this command without using dummy cycles. NOTE Modes indicated as not supported may still be supported by the device, but not using the same number of dummy cycles as listed here. NOTE Other modes may also be supported by the device.</p>
15-8	<p>Command used for read access 00h means not supported</p>
7-0	<p>Command used for write access 00h means not supported</p>

6.10.12 SCCR Map for SPI Memory Devices Parameter Table: 10th DWORD – Variable Dummy Cycle Settings- Non Volatile Register

Bits	Description
31	Variable number of dummy cycles supported 0: Not supported, (or supported in a way that can't be described correctly by this parameter table) 1: Supported
30-29	Number of physical bits used to set dummy cycles See the following DWORDs for bit patterns used to set dummy cycles (wait states) 00: 2 bit 01: 3 bits 10: 4 bit 11: 5 bits
28	Bits are accessed by commands using address 0: Bits are accessed by direct commands (Commands do not use address) 1: Bits are accessed by commands using address
27	0: Local address for Variable Dummy Cycle Settings bits is found in last byte of the address: (Byte 0 of 32-bit address space): xxxx-xxxx xxxx-xxxx xxxx-xxxx AAAA-AAAA (Byte 0 of 24-bit address space): xxxx-xxxx xxxx-xxxx AAAA-AAAA (Byte 0 of 8-bit address space): AAAA-AAAA 1: Local address for Variable Dummy Cycle Settings bits is found in Byte 1 of 32-bit address: xxxx-xxxx xxxx-xxxx AAAA-AAAA xxxx-xxxx (This option may also be used for 24-bit addressing, but is not applicable for devices using 8-bit addressing)
26-24	Bit location of LSB of physical bits in register (Requirements: The physical bits used in a device are in the same (one) register, the bits form a continuous field and the bits are in order. If these requirements are not met, bit 31 above has to be set to 0.)
23-16	If Bit 28 is 1: Address of registers where bits are located Local address AAAA-AAAA If Bit 28 is 0: Modes supported and dummy cycles used for direct command Bit 23: 1: 8D-8D-8D mode supported, using the # of dummy cycles shown in bits 19-16 0: 8D-8D-8D mode not supported, using the # of dummy cycles shown in bits 19-16 Bit 22: 1: 8S-8S-8S mode supported, using the # of dummy cycles shown in bits 19-16 0: 8S-8S-8S mode not supported, using the # of dummy cycles shown in bits 19-16 Bit 21: 1: 4S-4D-4D mode supported, using the # of dummy cycles shown in bits 19-16 0: 4S-4D-4D mode not supported, using the # of dummy cycles shown in bits 19-16 Bit 20: 1: 4S-4S-4S mode supported, using the # of dummy cycles shown in bits 19-16 0: 4S-4S-4S mode not supported, using the # of dummy cycles shown in bits 19-16 Bits 19-16: Number of dummy cycles (0-15) used NOTE 1-1-1 mode, if supported by the device, will be supporting this command without using dummy cycles. NOTE Modes indicated as not supported may still be supported by the device, but not using the same number of dummy cycles as listed here. NOTE Other modes may also be supported by the device.
15-8	Command used for read access 00h means not supported
7-0	Command used for write access 00h means not supported

6.10.13 SCCR Map for SPI Memory Devices Parameter Table: 11th DWORD – Variable Dummy Cycle Settings – bit patterns

Bits	Description
31	30 dummy cycles supported: 0: Not supported 1: Supported
30-26	Bit pattern used to set 30 dummy cycles: If less than 5 physical bits are used to set dummy cycles, the least significant bits are used, and the most significant bit(s) are set to 0.
25	28 dummy cycles supported: 0: Not supported 1: Supported
24-20	Bit pattern used to set 28 dummy cycles: If less than 5 physical bits are used to set dummy cycles, the least significant bits are used, and the most significant bit(s) are set to 0.
19	26 dummy cycles supported: 0: Not supported 1: Supported
18-14	Bit pattern used to set 26 dummy cycles: If less than 5 physical bits are used to set dummy cycles, the least significant bits are used, and the most significant bit(s) are set to 0.
13	24 dummy cycles supported: 0: Not supported 1: Supported
12-8	Bit pattern used to set 24 dummy cycles: If less than 5 physical bits are used to set dummy cycles, the least significant bits are used, and the most significant bit(s) are set to 0.
7	22 dummy cycles supported: 0: Not supported 1: Supported
6-2	Bit pattern used to set 22 dummy cycles: If less than 5 physical bits are used to set dummy cycles, the least significant bits are used, and the most significant bit(s) are set to 0.
1-0	Reserved. Leave as “0”. (This allows new features to be added to these bits in the future.)

6.10.14 SCCR Map for SPI Memory Devices Parameter Table: 12th DWORD – Variable Dummy Cycle Settings – bit patterns

Bits	Description
31	20 dummy cycles supported: 0: Not supported 1: Supported
30-26	Bit pattern used to set 20 dummy cycles: If less than 5 physical bits are used to set dummy cycles, the least significant bits are used, and the most significant bit(s) are set to 0.
25	18 dummy cycles supported: 0: Not supported 1: Supported
24-20	Bit pattern used to set 18 dummy cycles: If less than 5 physical bits are used to set dummy cycles, the least significant bits are used, and the most significant bit(s) are set to 0.
19	16 dummy cycles supported: 0: Not supported 1: Supported
18-14	Bit pattern used to set 16 dummy cycles: If less than 5 physical bits are used to set dummy cycles, the least significant bits are used, and the most significant bit(s) are set to 0.
13	14 dummy cycles supported: 0: Not supported 1: Supported
12-8	Bit pattern used to set 14 dummy cycles: If less than 5 physical bits are used to set dummy cycles, the least significant bits are used, and the most significant bit(s) are set to 0.
7	12 dummy cycles supported: 0: Not supported 1: Supported
6-2	Bit pattern used to set 12 dummy cycles: If less than 5 physical bits are used to set dummy cycles, the least significant bits are used, and the most significant bit(s) are set to 0.
1-0	Reserved. Leave as “0”. (This allows new features to be added to these bits in the future.)

6.10.15 SCCR Map for SPI Memory Devices Parameter Table: 13th DWORD – Variable Dummy Cycle Settings – bit patterns

Bits	Description
31	10 dummy cycles supported: 0: Not supported 1: Supported
30-26	Bit pattern used to set 10 dummy cycles: If less than 5 physical bits are used to set dummy cycles, the least significant bits are used, and the most significant bit(s) are set to 0.
25	8 dummy cycles supported: 0: Not supported 1: Supported
24-20	Bit pattern used to set 8 dummy cycles: If less than 5 physical bits are used to set dummy cycles, the least significant bits are used, and the most significant bit(s) are set to 0.
19	6 dummy cycles supported: 0: Not supported 1: Supported
18-14	Bit pattern used to set 6 dummy cycles: If less than 5 physical bits are used to set dummy cycles, the least significant bits are used, and the most significant bit(s) are set to 0.
13	4 dummy cycles supported: 0: Not supported 1: Supported
12-8	Bit pattern used to set 4 dummy cycles: If less than 5 physical bits are used to set dummy cycles, the least significant bits are used, and the most significant bit(s) are set to 0.
7	2 dummy cycles supported: 0: Not supported 1: Supported
6-2	Bit pattern used to set 2 dummy cycles: If less than 5 physical bits are used to set dummy cycles, the least significant bits are used, and the most significant bit(s) are set to 0.
1-0	Reserved. Leave as “0”. (This allows new features to be added to these bits in the future.)

6.10.16 SCCR Map for SPI Memory Devices Parameter Table: 14th DWORD – QPI Mode Enable Volatile

Bits	Description
31	QPI Mode Enable bit available: 0: Not supported 1: Supported
30	QPI Mode Enable bit polarity: 0: Positive (QPI Mode Enable bit = 1 means QPI mode is enabled) 1: Inverted (QPI Mode Enable bit = 0 means QPI mode is enabled)
29	Reserved. Leave as “0”. (This allows new features to be added to these bits in the future.)
28	Bit is accessed by commands using address 0: Bit is accessed by direct commands (Commands do not use address) 1: Bit is accessed by commands using address
27	0: Local address for QPI Mode Enable bit is found in last byte of the address: (Byte 0 of 32-bit address space): xxxx-xxxx xxxx-xxxx xxxx-xxxx AAAA-AAAA (Byte 0 of 24-bit address space): xxxx-xxxx xxxx-xxxx AAAA-AAAA (Byte 0 of 8-bit address space): AAAA-AAAA 1: Local address for QPI Mode Enable bit is found in Byte 1 of 32-bit address: xxxx-xxxx xxxx-xxxx AAAA-AAAA xxxx-xxxx (This option may also be used for 24-bit addressing, but is not applicable for devices using 8-bit addressing)
26-24	Bit location of QPI Mode Enable bit in register
23-16	If Bit 28 is 1: Address of register where bit is located Local address AAAA-AAAA If Bit 28 is 0: Modes supported and dummy cycles used for direct command Bit 23: 1: 8D-8D-8D mode supported, using the # of dummy cycles shown in bits 19-16 0: 8D-8D-8D mode not supported, using the # of dummy cycles shown in bits 19-16 Bit 22: 1: 8S-8S-8S mode supported, using the # of dummy cycles shown in bits 19-16 0: 8S-8S-8S mode not supported, using the # of dummy cycles shown in bits 19-16 Bit 21: 1: 4S-4D-4D mode supported, using the # of dummy cycles shown in bits 19-16 0: 4S-4D-4D mode not supported, using the # of dummy cycles shown in bits 19-16 Bit 20: 1: 4S-4S-4S mode supported, using the # of dummy cycles shown in bits 19-16 0: 4S-4S-4S mode not supported, using the # of dummy cycles shown in bits 19-16 Bits 19-16: Number of dummy cycles (0-15) used NOTE 1-1-1 mode, if supported by the device, will be supporting this command without using dummy cycles. NOTE Modes indicated as not supported may still be supported by the device, but not using the same number of dummy cycles as listed here. NOTE Other modes may also be supported by the device.
15-8	Command used for read access 00h means not supported
7-0	Command used for write access 00h means not supported

6.10.17 SCCR Map for SPI Memory Devices Parameter Table: 15th DWORD – QPI Mode Enable - Non Volatile

Bits	Description
31	QPI Mode Enable bit available: 0: Not supported 1: Supported
30	QPI Mode Enable bit polarity: 0: Positive (QPI Mode Enable bit = 1 means QPI mode is enabled) 1: Inverted (QPI Mode Enable bit = 0 means QPI mode is enabled)
29	Reserved. Leave as “0”. (This allows new features to be added to these bits in the future.)
28	Bit is accessed by commands using address 0: Bit is accessed by direct commands (Commands do not use address) 1: Bit is accessed by commands using address
27	0: Local address for QPI Mode Enable bit is found in last byte of the address (Byte 0 of 32-bit address space): xxxx-xxxx xxxx-xxxx xxxx-xxxx AAAA-AAAA (Byte 0 of 24-bit address space): xxxx-xxxx xxxx-xxxx AAAA-AAAA (Byte 0 of 8-bit address space): AAAA-AAAA 1: Local address for QPI Mode Enable bit is found in Byte 1 of 32-bit address: xxxx-xxxx xxxx-xxxx AAAA-AAAA xxxx-xxxx (This option may also be used for 24-bit addressing, but is not applicable for devices using 8-bit addressing)
26-24	Bit location of QPI Mode Enable bit in register
23-16	If Bit 28 is 1: Address of register where bit is located Local address AAAA-AAAA If Bit 28 is 0: Modes supported and dummy cycles used for direct command Bit 23: 1: 8D-8D-8D mode supported, using the # of dummy cycles shown in bits 19-16 0: 8D-8D-8D mode not supported, using the # of dummy cycles shown in bits 19-16 Bit 22: 1: 8S-8S-8S mode supported, using the # of dummy cycles shown in bits 19-16 0: 8S-8S-8S mode not supported, using the # of dummy cycles shown in bits 19-16 Bit 21: 1: 4S-4D-4D mode supported, using the # of dummy cycles shown in bits 19-16 0: 4S-4D-4D mode not supported, using the # of dummy cycles shown in bits 19-16 Bit 20: 1: 4S-4S-4S mode supported, using the # of dummy cycles shown in bits 19-16 0: 4S-4S-4S mode not supported, using the # of dummy cycles shown in bits 19-16 Bits 19-16: Number of dummy cycles (0-15) used NOTE 1-1-1 mode, if supported by the device, will be supporting this command without using dummy cycles. NOTE Modes indicated as not supported may still be supported by the device, but not using the same number of dummy cycles as listed here. NOTE Other modes may also be supported by the device.
15-8	Command used for read access 00h means not supported
7-0	Command used for write access 00h means not supported

6.10.18 SCCR Map for SPI Memory Devices Parameter Table: 16th DWORD – Octal Mode Enable - Volatile

Bits	Description
31	Octal Mode Enable Volatile bit available: 0: Not supported 1: Supported
30	Octal Mode Enable Volatile bit polarity: 0: Positive (Octal Mode Enable bit = 1 means Octal mode is enabled) 1: Inverted (Octal Mode Enable bit = 0 means Octal mode is enabled)
29	Reserved. Leave as “0”. (This allows new features to be added to these bits in the future.)
28	Bit is accessed by commands using address 0: Bit is accessed by direct commands (Commands do not use address) 1: Bit is accessed by commands using address
27	0: Local address for Octal Mode Enable Volatile bit is found in last byte of the address: (Byte 0 of 32-bit address space): xxxx-xxxx xxxx-xxxx xxxx-xxxx AAAA-AAAA (Byte 0 of 24-bit address space): xxxx-xxxx xxxx-xxxx AAAA-AAAA (Byte 0 of 8-bit address space): AAAA-AAAA 1: Local address for Octal Mode Enable Volatile bit is found in Byte 1 of 32-bit address: xxxx-xxxx xxxx-xxxx AAAA-AAAA xxxx-xxxx (This option may also be used for 24-bit addressing, but is not applicable for devices using 8-bit addressing)
26-24	Bit location of Octal Mode Enable Volatile bit in register
23-16	If Bit 28 is 1: Address of register where bit is located Local address AAAA-AAAA If Bit 28 is 0: Modes supported and dummy cycles used for direct command Bit 23: 1: 8D-8D-8D mode supported, using the # of dummy cycles shown in bits 19-16 0: 8D-8D-8D mode not supported, using the # of dummy cycles shown in bits 19-16 Bit 22: 1: 8S-8S-8S mode supported, using the # of dummy cycles shown in bits 19-16 0: 8S-8S-8S mode not supported, using the # of dummy cycles shown in bits 19-16 Bit 21: 1: 4S-4D-4D mode supported, using the # of dummy cycles shown in bits 19-16 0: 4S-4D-4D mode not supported, using the # of dummy cycles shown in bits 19-16 Bit 20: 1: 4S-4S-4S mode supported, using the # of dummy cycles shown in bits 19-16 0: 4S-4S-4S mode not supported, using the # of dummy cycles shown in bits 19-16 Bits 19-16: Number of dummy cycles (0-15) used NOTE 1-1-1 mode, if supported by the device, will be supporting this command without using dummy cycles. NOTE Modes indicated as not supported may still be supported by the device, but not using the same number of dummy cycles as listed here. NOTE Other modes may also be supported by the device.
15-8	Command used for read access 00h means not supported
7-0	Command used for write access 00h means not supported

6.10.19 SCCR Map for SPI Memory Devices Parameter Table: 17th DWORD – Octal Mode Enable-Non-Volatile

Bits	Description
31	Octal Mode Enable Non-Volatile bit available: 0: Not supported 1: Supported
30	Octal Mode Enable Non-Volatile bit polarity: 0: Positive (Octal Mode Enable bit = 1 means Octal mode is enabled) 1: Inverted (Octal Mode Enable bit = 0 means Octal mode is enabled)
29	OTP bit 0: Bit can be changed multiple times 1: Bit is an OTP bit that can only be set once.
28	Bit is accessed by commands using address 0: Bit is accessed by direct commands (Commands do not use address) 1: Bit is accessed by commands using address
27	0: Local address for Octal Mode Enable Non-Volatile bit is found in last byte of the address: (Byte 0 of 32-bit address space): xxxx-xxxx xxxx-xxxx xxxx-xxxx AAAA-AAAA (Byte 0 of 24-bit address space): xxxx-xxxx xxxx-xxxx AAAA-AAAA (Byte 0 of 8-bit address space): AAAA-AAAA 1: Local address for Octal Mode Enable Non-Volatile bit is found in Byte 1 of 32-bit address: xxxx-xxxx xxxx-xxxx AAAA-AAAA xxxx-xxxx (This option may also be used for 24-bit addressing, but is not applicable for devices using 8-bit addressing)
26-24	Bit location of Octal Mode Enable Non-Volatile bit in register
23-16	If Bit 28 is 1: Address of register where bit is located Local address AAAA-AAAA If Bit 28 is 0: Modes supported and dummy cycles used for direct command Bit 23: 1: 8D-8D-8D mode supported, using the # of dummy cycles shown in bits 19-16 0: 8D-8D-8D mode not supported, using the # of dummy cycles shown in bits 19-16 Bit 22: 1: 8S-8S-8S mode supported, using the # of dummy cycles shown in bits 19-16 0: 8S-8S-8S mode not supported, using the # of dummy cycles shown in bits 19-16 Bit 21: 1: 4S-4D-4D mode supported, using the # of dummy cycles shown in bits 19-16 0: 4S-4D-4D mode not supported, using the # of dummy cycles shown in bits 19-16 Bit 20: 1: 4S-4S-4S mode supported, using the # of dummy cycles shown in bits 19-16 0: 4S-4S-4S mode not supported, using the # of dummy cycles shown in bits 19-16 Bits 19-16: Number of dummy cycles (0-15) used NOTE 1-1-1 mode, if supported by the device, will be supporting this command without using dummy cycles. NOTE Modes indicated as not supported may still be supported by the device, but not using the same number of dummy cycles as listed here. NOTE Other modes may also be supported by the device.
15-8	Command used for read access 00h means not supported
7-0	Command used for write access 00h means not supported

6.10.20 SCCR Map for SPI Memory Devices Parameter Table: 18th DWORD – STR or DTR mode select - Volatile

Bits	Description
31	STR or DTR mode select Volatile bit available: 0: Not supported 1: Supported
30	STR or DTR mode select Volatile bit polarity: 0: Positive (STR or DTR mode select bit = 0 means STR mode, 1 means DTR mode) 1: Inverted (STR or DTR mode select bit = 1 means STR mode, 0 means DTR mode)
29	Reserved. Leave as “0”. (This allows new features to be added to these bits in the future.)
28	Bit is accessed by commands using address 0: Bit is accessed by direct commands (Commands do not use address) 1: Bit is accessed by commands using address
27	0: Local address for STR or DTR mode select Volatile bit is found in last byte of the address: (Byte 0 of 32-bit address space): xxxx-xxxx xxxx-xxxx xxxx-xxxx AAAA-AAAA (Byte 0 of 24-bit address space): xxxx-xxxx xxxx-xxxx AAAA-AAAA (Byte 0 of 8-bit address space): AAAA-AAAA 1: Local address for STR or DTR mode select Volatile bit is found in Byte 1 of 32-bit address: xxxx-xxxx xxxx-xxxx AAAA-AAAA xxxx-xxxx (This option may also be used for 24-bit addressing, but is not applicable for devices using 8-bit addressing)
26-24	Bit location of STR or DTR mode select Volatile bit in register
23-16	If Bit 28 is 1: Address of register where bit is located Local address AAAA-AAAA If Bit 28 is 0: Modes supported and dummy cycles used for direct command Bit 23: 1: 8D-8D-8D mode supported, using the # of dummy cycles shown in bits 19-16 0: 8D-8D-8D mode not supported, using the # of dummy cycles shown in bits 19-16 Bit 22: 1: 8S-8S-8S mode supported, using the # of dummy cycles shown in bits 19-16 0: 8S-8S-8S mode not supported, using the # of dummy cycles shown in bits 19-16 Bit 21: 1: 4S-4D-4D mode supported, using the # of dummy cycles shown in bits 19-16 0: 4S-4D-4D mode not supported, using the # of dummy cycles shown in bits 19-16 Bit 20: 1: 4S-4S-4S mode supported, using the # of dummy cycles shown in bits 19-16 0: 4S-4S-4S mode not supported, using the # of dummy cycles shown in bits 19-16 Bits 19-16: Number of dummy cycles (0-15) used NOTE 1-1-1 mode, if supported by the device, will be supporting this command without using dummy cycles. NOTE Modes indicated as not supported may still be supported by the device, but not using the same number of dummy cycles as listed here. NOTE Other modes may also be supported by the device.
15-8	Command used for read access 00h means not supported
7-0	Command used for write access 00h means not supported

6.10.21 SCCR Map for SPI Memory Devices Parameter Table: 19th DWORD – STR or DTR mode select – Non Volatile

Bits	Description
31	STR or DTR mode select Non Volatile bit available: 0: Not supported 1: Supported
30	STR or DTR mode select Non Volatile bit polarity: 0: Positive (STR or DTR mode select bit = 0 means STR mode, 1 means DTR mode) 1: Inverted (STR or DTR mode select bit = 1 means STR mode, 0 means DTR mode)
29	Reserved. Leave as “0”. (This allows new features to be added to these bits in the future.)
28	Bit is accessed by commands using address 0: Bit is accessed by direct commands (Commands do not use address) 1: Bit is accessed by commands using address
27	0: Local address for STR or DTR mode select Non Volatile bit is found in last byte of the address: (Byte 0 of 32-bit address space): xxxx-xxxx xxxx-xxxx xxxx-xxxx AAAA-AAAA (Byte 0 of 24-bit address space): xxxx-xxxx xxxx-xxxx AAAA-AAAA (Byte 0 of 8-bit address space): AAAA-AAAA 1: Local address for STR or DTR mode select Non Volatile bit is found in Byte 1 of 32-bit address: xxxx-xxxx xxxx-xxxx AAAA-AAAA xxxx-xxxx (This option may also be used for 24-bit addressing, but is not applicable for devices using 8-bit addressing)
26-24	Bit location of STR or DTR mode select Non Volatile bit in register
23-16	If Bit 28 is 1: Address of register where bit is located Local address AAAA-AAAA If Bit 28 is 0: Modes supported and dummy cycles used for direct command Bit 23: 1: 8D-8D-8D mode supported, using the # of dummy cycles shown in bits 19-16 0: 8D-8D-8D mode not supported, using the # of dummy cycles shown in bits 19-16 Bit 22: 1: 8S-8S-8S mode supported, using the # of dummy cycles shown in bits 19-16 0: 8S-8S-8S mode not supported, using the # of dummy cycles shown in bits 19-16 Bit 21: 1: 4S-4D-4D mode supported, using the # of dummy cycles shown in bits 19-16 0: 4S-4D-4D mode not supported, using the # of dummy cycles shown in bits 19-16 Bit 20: 1: 4S-4S-4S mode supported, using the # of dummy cycles shown in bits 19-16 0: 4S-4S-4S mode not supported, using the # of dummy cycles shown in bits 19-16 Bits 19-16: Number of dummy cycles (0-15) used NOTE 1-1-1 mode, if supported by the device, will be supporting this command without using dummy cycles. NOTE Modes indicated as not supported may still be supported by the device, but not using the same number of dummy cycles as listed here. NOTE Other modes may also be supported by the device.
15-8	Command used for read access 00h means not supported
7-0	Command used for write access 00h means not supported

6.10.22 SCCR Map for SPI Memory Devices Parameter Table: 20th DWORD – STR Octal Mode Enable - Volatile

Bits	Description
31	STR Octal Mode Enable Volatile bit available: 0: Not supported 1: Supported
30	STR Octal Mode Enable Volatile bit polarity: 0: Positive (STR Octal Mode Enable = 1 means STR Octal Mode is enabled) 1: Inverted (STR Octal Mode Enable = 0 means STR Octal Mode is enabled)
29	Reserved. Leave as “0”. (This allows new features to be added to these bits in the future.)
28	Bit is accessed by commands using address 0: Bit is accessed by direct commands (Commands do not use address) 1: Bit is accessed by commands using address
27	0: Local address for STR Octal Mode Enable Volatile bit is found in last byte of the address (Byte 0 of 32-bit address space): xxxx-xxxx xxxx-xxxx xxxx-xxxx AAAA-AAAA (Byte 0 of 24-bit address space): xxxx-xxxx xxxx-xxxx AAAA-AAAA (Byte 0 of 8-bit address space): AAAA-AAAA 1: Local address for STR Octal Mode Enable Volatile bit is found in Byte 1 of 32-bit address: xxxx-xxxx xxxx-xxxx AAAA-AAAA xxxx-xxxx (This option may also be used for 24-bit addressing, but is not applicable for devices using 8-bit addressing)
26-24	Bit location of STR Octal Mode Enable Volatile bit in register
23-16	If Bit 28 is 1: Address of register where bit is located Local address AAAA-AAAA If Bit 28 is 0: Modes supported and dummy cycles used for direct command Bit 23: 1: 8D-8D-8D mode supported, using the # of dummy cycles shown in bits 19-16 0: 8D-8D-8D mode not supported, using the # of dummy cycles shown in bits 19-16 Bit 22: 1: 8S-8S-8S mode supported, using the # of dummy cycles shown in bits 19-16 0: 8S-8S-8S mode not supported, using the # of dummy cycles shown in bits 19-16 Bit 21: 1: 4S-4D-4D mode supported, using the # of dummy cycles shown in bits 19-16 0: 4S-4D-4D mode not supported, using the # of dummy cycles shown in bits 19-16 Bit 20: 1: 4S-4S-4S mode supported, using the # of dummy cycles shown in bits 19-16 0: 4S-4S-4S mode not supported, using the # of dummy cycles shown in bits 19-16 Bits 19-16: Number of dummy cycles (0-15) used NOTE 1-1-1 mode, if supported by the device, will be supporting this command without using dummy cycles. NOTE Modes indicated as not supported may still be supported by the device, but not using the same number of dummy cycles as listed here. NOTE Other modes may also be supported by the device.
15-8	Command used for read access 00h means not supported
7-0	Command used for write access 00h means not supported

6.10.23 SCCR Map for SPI Memory Devices Parameter Table: 21st DWORD – STR Octal Mode Enable - Non-Volatile

Bits	Description
31	STR Octal Mode Enable Non-Volatile bit available: 0: Not supported 1: Supported
30	STR Octal Mode Enable Non-Volatile bit polarity: 0: Positive (STR Octal Mode Enable = 1 means STR Octal Mode is enabled) 1: Inverted (STR Octal Mode Enable = 0 means STR Octal Mode is enabled)
29	OTP bit 0: STR Octal Mode Enable Non-Volatile Bit can be changed multiple times 1: STR Octal Mode Enable Non-Volatile Bit is an OTP bit that can only be set once.
28	Bit is accessed by commands using address 0: Bit is accessed by direct commands (Commands do not use address) 1: Bit is accessed by commands using address
27	0: Local address for STR Octal Mode Enable Non-Volatile bit is found in last byte of the address (Byte 0 of 32-bit address space): xxxx-xxxx xxxx-xxxx xxxx-xxxx AAAA-AAAA (Byte 0 of 24-bit address space): xxxx-xxxx xxxx-xxxx AAAA-AAAA (Byte 0 of 8-bit address space): AAAA-AAAA 1: Local address for STR Octal Mode Enable Non-Volatile bit is found in Byte 1 of 32-bit address: xxxx-xxxx xxxx-xxxx AAAA-AAAA xxxx-xxxx (This option may also be used for 24-bit addressing, but is not applicable for devices using 8-bit addressing)
26-24	Bit location of STR Octal Mode Enable Non-Volatile bit in register
23-16	If Bit 28 is 1: Address of register where bit is located Local address AAAA-AAAA If Bit 28 is 0: Modes supported and dummy cycles used for direct command Bit 23: 1: 8D-8D-8D mode supported, using the # of dummy cycles shown in bits 19-16 0: 8D-8D-8D mode not supported, using the # of dummy cycles shown in bits 19-16 Bit 22: 1: 8S-8S-8S mode supported, using the # of dummy cycles shown in bits 19-16 0: 8S-8S-8S mode not supported, using the # of dummy cycles shown in bits 19-16 Bit 21: 1: 4S-4D-4D mode supported, using the # of dummy cycles shown in bits 19-16 0: 4S-4D-4D mode not supported, using the # of dummy cycles shown in bits 19-16 Bit 20: 1: 4S-4S-4S mode supported, using the # of dummy cycles shown in bits 19-16 0: 4S-4S-4S mode not supported, using the # of dummy cycles shown in bits 19-16 Bits 19-16: Number of dummy cycles (0-15) used NOTE 1-1-1 mode, if supported by the device, will be supporting this command without using dummy cycles. NOTE Modes indicated as not supported may still be supported by the device, but not using the same number of dummy cycles as listed here. NOTE Other modes may also be supported by the device.
15-8	Command used for read access 00h means not supported
7-0	Command used for write access 00h means not supported

6.10.24 SCCR Map for SPI Memory Devices Parameter Table: 22nd DWORD – DTR Octal Mode Enable - Volatile

Bits	Description
31	DTR Octal Mode Enable Volatile bit available: 0: Not supported 1: Supported
30	DTR Octal Mode Enable Volatile bit polarity: 0: Positive (DSTR Octal Mode Enable = 1 means DTR Octal Mode is enabled) 1: Inverted (DTR Octal Mode Enable = 0 means DTR Octal Mode is enabled)
29	Reserved. Leave as “0”. (This allows new features to be added to these bits in the future.)
28	Bit is accessed by commands using address 0: Bit is accessed by direct commands (Commands do not use address) 1: Bit is accessed by commands using address
27	0: Local address for DTR Octal Mode Enable - Volatile bit is found in last byte of the address: (Byte 0 of 32-bit address space): xxxx-xxxx xxxx-xxxx xxxx-xxxx AAAA-AAAA (Byte 0 of 24-bit address space): xxxx-xxxx xxxx-xxxx AAAA-AAAA (Byte 0 of 8-bit address space): AAAA-AAAA 1: Local address for DTR Octal Mode Enable - Volatile bit is found in Byte 1 of 32-bit address: xxxx-xxxx xxxx-xxxx AAAA-AAAA xxxx-xxxx (This option may also be used for 24-bit addressing, but is not applicable for devices using 8-bit addressing)
26-24	Bit location of STR Octal Mode Enable Volatile bit in register
23-16	If Bit 28 is 1: Address of register where bit is located Local address AAAA-AAAA If Bit 28 is 0: Modes supported and dummy cycles used for direct command Bit 23: 1: 8D-8D-8D mode supported, using the # of dummy cycles shown in bits 19-16 0: 8D-8D-8D mode not supported, using the # of dummy cycles shown in bits 19-16 Bit 22: 1: 8S-8S-8S mode supported, using the # of dummy cycles shown in bits 19-16 0: 8S-8S-8S mode not supported, using the # of dummy cycles shown in bits 19-16 Bit 21: 1: 4S-4D-4D mode supported, using the # of dummy cycles shown in bits 19-16 0: 4S-4D-4D mode not supported, using the # of dummy cycles shown in bits 19-16 Bit 20: 1: 4S-4S-4S mode supported, using the # of dummy cycles shown in bits 19-16 0: 4S-4S-4S mode not supported, using the # of dummy cycles shown in bits 19-16 Bits 19-16: Number of dummy cycles (0-15) used NOTE 1-1-1 mode, if supported by the device, will be supporting this command without using dummy cycles. NOTE Modes indicated as not supported may still be supported by the device, but not using the same number of dummy cycles as listed here. NOTE Other modes may also be supported by the device.
15-8	Command used for read access 00h means not supported
7-0	Command used for write access 00h means not supported

6.10.25 SCCR Map for SPI Memory Devices Parameter Table: 23rd DWORD – DTR Octal Mode Enable – Non-Volatile

Bits	Description
31	DTR Octal Mode Enable Non-Volatile bit available: 0: Not supported 1: Supported
30	DTR Octal Mode Enable Non-Volatile bit polarity: 0: Positive (DSTR Octal Mode Enable = 1 means DTR Octal Mode is enabled) 1: Inverted (DTR Octal Mode Enable = 0 means DTR Octal Mode is enabled)
29	OTP bit 0: DTR Octal Mode Enable – Non-Volatile Bit can be changed multiple times 1: DTR Octal Mode Enable – Non-Volatile Bit is an OTP bit that can only be set once.
28	Bit is accessed by commands using address 0: Bit is accessed by direct commands (Commands do not use address) 1: Bit is accessed by commands using address
27	0: Local address for DTR Octal Mode Enable – Non-Volatile bit is found in last byte of the address (Byte 0 of 32-bit address space): xxxx-xxxx xxxx-xxxx xxxx-xxxx AAAA-AAAA (Byte 0 of 24-bit address space): xxxx-xxxx xxxx-xxxx AAAA-AAAA (Byte 0 of 8-bit address space): AAAA-AAAA 1: Local address for DTR Octal Mode Enable – Non-Volatile bit is found in Byte 1 of 32-bit address: xxxx-xxxx xxxx-xxxx AAAA-AAAA xxxx-xxxx (This option may also be used for 24-bit addressing, but is not applicable for devices using 8-bit addressing)
26-24	Bit location of STR Octal Mode Enable Non-Volatile bit in register
23-16	If Bit 28 is 1: Address of register where bit is located Local address AAAA-AAAA If Bit 28 is 0: Modes supported and dummy cycles used for direct command Bit 23: 1: 8D-8D-8D mode supported, using the # of dummy cycles shown in bits 19-16 0: 8D-8D-8D mode not supported, using the # of dummy cycles shown in bits 19-16 Bit 22: 1: 8S-8S-8S mode supported, using the # of dummy cycles shown in bits 19-16 0: 8S-8S-8S mode not supported, using the # of dummy cycles shown in bits 19-16 Bit 21: 1: 4S-4D-4D mode supported, using the # of dummy cycles shown in bits 19-16 0: 4S-4D-4D mode not supported, using the # of dummy cycles shown in bits 19-16 Bit 20: 1: 4S-4S-4S mode supported, using the # of dummy cycles shown in bits 19-16 0: 4S-4S-4S mode not supported, using the # of dummy cycles shown in bits 19-16 Bits 19-16: Number of dummy cycles (0-15) used NOTE 1-1-1 mode, if supported by the device, will be supporting this command without using dummy cycles. NOTE Modes indicated as not supported may still be supported by the device, but not using the same number of dummy cycles as listed here. NOTE Other modes may also be supported by the device.
15-8	Command used for read access 00h means not supported
7-0	Command used for write access 00h means not supported

6.10.26 SCCR Map for SPI Memory Devices Parameter Table: 24th DWORD – DPD Status

Bits	Description
31	Deep Power-Down (DPD) Status bit available: 0: Not supported 1: Supported
30	Deep Power-Down (DPD) Status bit polarity: 0: Positive (DPD Status = 0 means device is in Deep Power-Down) 1: Inverted (DPD Status = 1 means device is in Deep Power-Down)
29	Reserved. Leave as “0”. (This allows new features to be added to these bits in the future.)
28	Bit is accessed by commands using address 0: Bit is accessed by direct commands (Commands do not use address) 1: Bit is accessed by commands using address
27	0: Local address for DPD Status bit is found in last byte of the address: (Byte 0 of 32-bit address space): xxxx-xxxx xxxx-xxxx xxxx-xxxx AAAA-AAAA (Byte 0 of 24-bit address space): xxxx-xxxx xxxx-xxxx AAAA-AAAA (Byte 0 of 8-bit address space): AAAA-AAAA 1: Local address for DPD Status bit is found in Byte 1 of 32-bit address: xxxx-xxxx xxxx-xxxx AAAA-AAAA xxxx-xxxx (This option may also be used for 24-bit addressing, but is not applicable for devices using 8-bit addressing)
26-24	Bit location of DPD Status bit in register
23-16	If Bit 28 is 1: Address of register where bit is located Local address AAAA-AAAA If Bit 28 is 0: Modes supported and dummy cycles used for direct command Bit 23: 1: 8D-8D-8D mode supported, using the # of dummy cycles shown in bits 19-16 0: 8D-8D-8D mode not supported, using the # of dummy cycles shown in bits 19-16 Bit 22: 1: 8S-8S-8S mode supported, using the # of dummy cycles shown in bits 19-16 0: 8S-8S-8S mode not supported, using the # of dummy cycles shown in bits 19-16 Bit 21: 1: 4S-4D-4D mode supported, using the # of dummy cycles shown in bits 19-16 0: 4S-4D-4D mode not supported, using the # of dummy cycles shown in bits 19-16 Bit 20: 1: 4S-4S-4S mode supported, using the # of dummy cycles shown in bits 19-16 0: 4S-4S-4S mode not supported, using the # of dummy cycles shown in bits 19-16 Bits 19-16: Number of dummy cycles (0-15) used NOTE 1-1-1 mode, if supported by the device, will be supporting this command without using dummy cycles. NOTE Modes indicated as not supported may still be supported by the device, but not using the same number of dummy cycles as listed here. NOTE Other modes may also be supported by the device.
15-8	Command used for read access 00h means not supported
7-0	Command used for write access 00h means not supported

6.10.27 SCCR Map for SPI Memory Devices Parameter Table: 25th DWORD – UDPD Status

Bits	Description
31	Ultra-Deep Power-Down (UDPD) Status bit available: 0: Not supported 1: Supported

30	Ultra-Deep Power-Down (UDPD) Status bit polarity: 0: Positive (UDPD Status bit = 0 means device is in Ultra-Deep Power-Down) 1: Inverted (UDPD Status bit = 1 means device is in Ultra-Deep Power-Down)
29	Reserved. Leave as “0”. (This allows new features to be added to these bits in the future.)
28	Bit is accessed by commands using address 0: Bit is accessed by direct commands (Commands do not use address) 1: Bit is accessed by commands using address
27	0: Local address for each bit is found in last byte of the address: (Byte 0 of 32-bit address space): xxxx-xxxx xxxx-xxxx xxxx-xxxx AAAA-AAAA (Byte 0 of 24-bit address space): xxxx-xxxx xxxx-xxxx AAAA-AAAA (Byte 0 of 8-bit address space): AAAA-AAAA 1: Local address for each bit is found in Byte 1 of 32-bit address: xxxx-xxxx xxxx-xxxx AAAA-AAAA xxxx-xxxx (This option may also be used for 24-bit addressing, but is not applicable for devices using 8-bit addressing)
26-24	Bit location of UDPD Status bit in register
23-16	If Bit 28 is 1: Address of register where bit is located Local address AAAA-AAAA If Bit 28 is 0: Modes supported and dummy cycles used for direct command Bit 23: 1: 8D-8D-8D mode supported, using the # of dummy cycles shown in bits 19-16 0: 8D-8D-8D mode not supported, using the # of dummy cycles shown in bits 19-16 Bit 22: 1: 8S-8S-8S mode supported, using the # of dummy cycles shown in bits 19-16 0: 8S-8S-8S mode not supported, using the # of dummy cycles shown in bits 19-16 Bit 21: 1: 4S-4D-4D mode supported, using the # of dummy cycles shown in bits 19-16 0: 4S-4D-4D mode not supported, using the # of dummy cycles shown in bits 19-16 Bit 20: 1: 4S-4S-4S mode supported, using the # of dummy cycles shown in bits 19-16 0: 4S-4S-4S mode not supported, using the # of dummy cycles shown in bits 19-16 Bits 19-16: Number of dummy cycles (0-15) used NOTE 1-1-1 mode, if supported by the device, will be supporting this command without using dummy cycles. NOTE Modes indicated as not supported may still be supported by the device, but not using the same number of dummy cycles as listed here. NOTE Other modes may also be supported by the device.
15-8	Command used for read access 00h means not supported
7-0	Command used for write access 00h means not supported

6.10.28 SCCR Map for SPI Memory Devices Parameter Table: 26th DWORD – Output Driver Strength - Volatile

See JEDEC Standard JESD251, *eXpanded Serial Peripheral Interface (xSPI) for Non Volatile Memory Devices*, for details about Output Driver Strength values.

Bits	Description
31-30	<p>Number of physical bits used to set Output Driver Strength 00: Control bits for Variable Output Driver Strength not available (or not available in a form that can be described in this format). 01: 1 bit 10: 2 bits 11: 3 bits</p>
29	<p>Reserved. Leave as “0”. (This allows new features to be added to these bits in the future.)</p>
28	<p>Bits are accessed by commands using address 0: Bits are accessed by direct commands (Commands do not use address) 1: Bits are accessed by commands using address</p>
27	<p>0: Local address for each bit is found in last byte of the address: (Byte 0 of 32-bit address space): xxxx-xxxx xxxx-xxxx xxxx-xxxx AAAA-AAAA (Byte 0 of 24-bit address space): xxxx-xxxx xxxx-xxxx AAAA-AAAA (Byte 0 of 8-bit address space): AAAA-AAAA 1: Local address for each bit is found in Byte 1 of 32-bit address: xxxx-xxxx xxxx-xxxx AAAA-AAAA xxxx-xxxx (This option may also be used for 24-bit addressing, but is not applicable for devices using 8-bit addressing)</p>
26-24	<p>Bit location of Least Significant Output Driver Strength bit in register</p>
23-16	<p>If Bit 28 is 1: Address of registers where bits are located Local address AAAA-AAAA If Bit 28 is 0: Modes supported and dummy cycles used for direct command Bit 23: 1: 8D-8D-8D mode supported, using the # of dummy cycles shown in bits 19-16 0: 8D-8D-8D mode not supported, using the # of dummy cycles shown in bits 19-16 Bit 22: 1: 8S-8S-8S mode supported, using the # of dummy cycles shown in bits 19-16 0: 8S-8S-8S mode not supported, using the # of dummy cycles shown in bits 19-16 Bit 21: 1: 4S-4D-4D mode supported, using the # of dummy cycles shown in bits 19-16 0: 4S-4D-4D mode not supported, using the # of dummy cycles shown in bits 19-16 Bit 20: 1: 4S-4S-4S mode supported, using the # of dummy cycles shown in bits 19-16 0: 4S-4S-4S mode not supported, using the # of dummy cycles shown in bits 19-16 Bits 19-16: Number of dummy cycles (0-15) used NOTE 1-1-1 mode, if supported by the device, will be supporting this command without using dummy cycles. NOTE Modes indicated as not supported may still be supported by the device, but not using the same number of dummy cycles as listed here. NOTE Other modes may also be supported by the device.</p>
15-8	<p>Command used for read access 00h means not supported</p>
7-0	<p>Command used for write access 00h means not supported</p>

6.10.29 SCCR Map for SPI Memory Devices Parameter Table: 27th DWORD – Output Driver Strength – Non Volatile

See JEDEC Standard JESD251, *eXpanded Serial Peripheral Interface (xSPI) for Non Volatile Memory Devices*, for details about Output Driver Strength values.

Bits	Description
31-30	<p>Number of physical bits used to set Output Driver Strength 00: Control bits for Variable Output Driver Strength not available (or not available in a form that can be described in this format). 01: 1 bit 10: 2 bits 11: 3 bits</p>
29	<p>Reserved. Leave as “0”. (This allows new features to be added to these bits in the future.)</p>
28	<p>Bits are accessed by commands using address 0: Bits are accessed by direct commands (Commands do not use address) 1: Bits are accessed by commands using address</p>
27	<p>0: Local address for each bit is found in last byte of the address: (Byte 0 of 32-bit address space): xxxx-xxxx xxxx-xxxx xxxx-xxxx AAAA-AAAA (Byte 0 of 24-bit address space): xxxx-xxxx xxxx-xxxx AAAA-AAAA (Byte 0 of 8-bit address space): AAAA-AAAA 1: Local address for each bit is found in Byte 1 of 32-bit address: xxxx-xxxx xxxx-xxxx AAAA-AAAA xxxx-xxxx (This option may also be used for 24-bit addressing, but is not applicable for devices using 8-bit addressing)</p>
26-24	<p>Bit location of Least Significant Output Driver Strength bit in register</p>
23-16	<p>If Bit 28 is 1: Address of registers where bits are located Local address AAAA-AAAA If Bit 28 is 0: Modes supported and dummy cycles used for direct command Bit 23: 1: 8D-8D-8D mode supported, using the # of dummy cycles shown in bits 19-16 0: 8D-8D-8D mode not supported, using the # of dummy cycles shown in bits 19-16 Bit 22: 1: 8S-8S-8S mode supported, using the # of dummy cycles shown in bits 19-16 0: 8S-8S-8S mode not supported, using the # of dummy cycles shown in bits 19-16 Bit 21: 1: 4S-4D-4D mode supported, using the # of dummy cycles shown in bits 19-16 0: 4S-4D-4D mode not supported, using the # of dummy cycles shown in bits 19-16 Bit 20: 1: 4S-4S-4S mode supported, using the # of dummy cycles shown in bits 19-16 0: 4S-4S-4S mode not supported, using the # of dummy cycles shown in bits 19-16 Bits 19-16: Number of dummy cycles (0-15) used NOTE 1-1-1 mode, if supported by the device, will be supporting this command without using dummy cycles. NOTE Modes indicated as not supported may still be supported by the device, but not using the same number of dummy cycles as listed here. NOTE Other modes may also be supported by the device.</p>
15-8	<p>Command used for read access 00h means not supported</p>
7-0	<p>Command used for write access 00h means not supported</p>

6.10.30 SCCR Map for SPI Memory Devices Parameter Table: 28th DWORD – Output Driver Strength control bit patterns

Bits	Description
31-29	Bit pattern to support Driver type 0 If less than 3 control bits are used to control Variable Output Driver Strength, the most significant bit(s) are unused and should be set to 0.
28-26	Bit pattern to support Driver type 1 If less than 3 control bits are used to control Variable Output Driver Strength, the most significant bit(s) are unused and should be set to 0.
25-23	Bit pattern to support Driver type 2 If less than 3 control bits are used to control Variable Output Driver Strength, the most significant bit(s) are unused and should be set to 0.
22-20	Bit pattern to support Driver type 3 If less than 3 control bits are used to control Variable Output Driver Strength, the most significant bit(s) are unused and should be set to 0.
19-17	Bit pattern to support Driver type 4 If less than 3 control bits are used to control Variable Output Driver Strength, the most significant bit(s) are unused and should be set to 0.
16-0	Reserved. Leave as “0”. (This allows new features to be added to these bits in the future.)

6.11 Status, Control and Configuration Register Map for xSPI Profile 2.0 Memory Devices

xSPI Profile 2.0 memory devices from different manufacturers can have widely different configurations for Status, Control and Configuration registers. The Status, Control and Configuration Register Map (SCCR Map for short) defines a common nomenclature for the most common register bits and their functions, and describes how the individual bits may be accessed for a specific device.

This section covers the SCCR Map for xSPI Profile 2.0 Octal memory devices. Single, Dual, Quad and xSPI Profile 1.0 Octal memory devices. are covered in 6.10.

The purpose of the SCCR Map is to provide a host controller with a minimum amount of information to be able to boot a system and load necessary code for the system to run. It is to be expected that the code loaded from the memory device will contain the necessary information required to achieve optimum performance from the device.

The register address is defined as a 32-bit address in the SCCR Map. For devices using less than 32 bits for Generic Addressable Read/Write Status/Control register commands, the uppermost bits should be ignored. (Sending a 32-bit address to a device expecting an 8-bit address will not produce the desired result.) The actual number of address bytes and the number of dummy bytes/dummy cycles used for Generic Addressable Read/Write Status/Control register commands by the device is provided in 6.11.5.

To avoid the need to provide a full 32-bit address for each bit, the addressing scheme in this table takes into account that every device uses a narrow range of addresses for the SCCR. The address is therefore defined as a 32-bit offset address pointer, which indicates the start of the address block, and an 8-bit local address, which indicates the position of each register within the block. The physical address of a register is found by adding the 32-bit offset address pointer and the 8-bit local address. Separate 32-bit offset address pointers are provided for volatile and non-volatile address blocks.

The 8-bit local address can either be added to the last byte of the 32-byte address, creating an address of the format xxxx-xxxx xxxx-xxxx xxxx-xxxx AAAA-AAAA.

The 8-bit local address can be added to Byte 1 of the 32-bit address, creating an address of the format xxxx-xxxx xxxx-xxxx AAAA-AAAA xxxx-xxxx.

Which of the two options is used is described in 6.11.5.

In the SCCR Map, each bit is defined separately. In an actual device, multiple of these bits will be combined into one physical register (e.g., the Status Register). The physical registers may also include additional bits that are not part of the current SCCR Map. **It is therefore important that the host controller reads the current value of the register and only changes the intended bits before writing the value back to the register to ensure that other functions are not affected.** (“Read-Modify-Write” operations may be used if available.)

Even though the Status, Control and Configuration Register Map was initially developed as part of the xSPI protocol spec, this information can also be added for other devices.

Registers may be status, control or configuration registers.

6.11.1 SCCR Map for xSPI Profile 2.0 Memory Devices Parameter Header: 1st DWORD

Bits	Description
31:24	Parameter Table Length This field specifies how many DWORDs are in the Parameter table. NOTE This field is 1's based. Therefore, 1 indicates 1 DWORD.
23:16	Parameter Table Major Revision Number This 8-bit field indicates the major revision number of the parameter table. The value in this field is 01h for this table defined by JESD216E revision (unchanged from JESD216D revision). NOTE The Major Revision of JEDEC defined parameter tables can only be modified by updates to this standard.
15:8	Parameter Table Minor Revision Number This 8-bit field indicates the minor revision number of the Status, Control and Configuration Register Map Parameter Table. The value in this field is 00h for this table defined by JESD216E revision (unchanged from JESD216E revision). NOTE The Minor Revision of the JEDEC owned parameter tables can only be modified by updates to this standard.
7:0	Parameter ID LSB The Status, Control and Configuration Register Map is assigned the ID LSB of 09h.

6.11.2 SCCR Map for xSPI Profile 2.0 Memory Devices Parameter Header: 2nd DWORD

Bits	Description
31:24	Parameter ID MSB The Status, Control and Configuration Register Map for xSPI Profile 2.0 Memory Devices is assigned the ID MSB of FFh.
23:0	Parameter Table Pointer (PTP) This address specifies the start of this header's Parameter Table in the SFDP structure. The address is in terms of bytes and must be DWORD-aligned.

6.11.3 SCCR Map for xSPI Profile 2.0 Memory Devices Parameter Table: 1st DWORD – Volatile registers address offset

Bits	Description
31:0	Address offset for volatile registers

6.11.4 SCCR Map for xSPI Profile 2.0 Memory Devices Parameter Table: 2nd DWORD – Non-Volatile registers address offset

Bits	Description
31:0	Address offset for non-volatile registers

6.11.5 SCCR Map for xSPI Profile 2.0 Memory Devices Parameter Table: 3rd DWORD – Generic Addressable Read/Write Status/Control register commands

Bits	Description
31	Generic Addressable Read Status/Control register command supported for all registers 0: Not supported for any register 1: Supported for all registers
30	Generic Addressable Write Status/Control register command supported for all registers 0: Not supported for any register 1: Supported for some all registers
29:28	Number of command/address bytes used for Generic Addressable Read/Write Status/Control register commands: 00: 6 bytes (48-bit) 01: Reserved 10: Reserved 11: Reserved
27:23	Number of dummy cycles used for Generic Addressable Read Status/Control volatile register command 00000-11111:[0-31 cycles]
22:18	Number of dummy cycles used for Generic Addressable Read Status/Control non-volatile register command 00000-11111:[0-31 cycles]
17	Work In Progress – Device Busy (WIP) bit available: 0: Not supported 1: Supported
16	Work In Progress – Device Busy (WIP) polarity: 0: Positive (WIP=1 means write is in progress) 1: Inverted (WIP=0 means write is in progress)
15	0: Local address for WIP bit is found in last byte of the command-address: (Byte 0 of 48-bit command-address space): xxxx-xxxx xxxx-xxxx-xxxx-xxxx-xxxx-xxxx xxxx-xxxx AAAA-AAAA 1: Local address for WIP bit is found in Byte 1 of 48-bit command-address: (Byte 0 of 48-bit command-address space): xxxx-xxxx xxxx-xxxx-xxxx-xxxx-xxxx-xxxx AAAA-AAAA xxxx-xxxx
14:11	Bit location of WIP bit in register
10:3	Address of register where WIP is located
2:0	Reserved. Leave as “0”. (This allows new features to be added to these bits in the future.)

6.11.6 SCCR Map for xSPI Profile 2.0 Memory Devices Parameter Table: 4th DWORD – Program Error

Bits	Description
31	Program Error bit available: 0: Not supported 1: Supported
30	Program Error bit polarity: 0: Positive (Program Error = 0 means no error, Program Error = 1 means last Program operation created an error) 1: Inverted (Program Error = 1 means no error, Program Error = 0 means last Program operation created an error)
29	0: Local address for Program Error bit is found in last byte of the command-address: (Byte 0 of 48-bit command-address space): xxxx-xxxx xxxx-xxxx-xxxx-xxxx-xxxx-xxxx xxxx-xxxx AAAA-AAAA 1: Local address for Program Error bit is found in Byte 1 of 48-bit command-address: (Byte 0 of 48-bit command-address space): xxxx-xxxx xxxx-xxxx-xxxx-xxxx-xxxx-xxxx AAAA-AAAA xxxx-xxxx
28	Sharing 0: Not shared: The device has separate bits for Program Error and Erase Error 1: Shared: The same bit is used for both Program Error and Erase Error
27:24	Bit location of Program Error bit in register
23:16	Address of register where Program Error is located
15:0	Reserved. Leave as “0”. (This allows new features to be added to these bits in the future.)

6.11.7 SCCR Map for xSPI Profile 2.0 Memory Devices Parameter Table: 5th DWORD – Erase Error

Bits	Description
31	Erase Error bit available: 0: Not supported 1: Supported
30	Erase Error bit polarity: 0: Positive (Erase Error = 0 means no error, Erase Error = 1 means last Erase operation created an error) 1: Inverted (Erase Error = 1 means no error, Erase Error = 0 means last Erase operation created an error)
29	0: Local address for Erase Error bit is found in last byte of the command-address: (Byte 0 of 48-bit command-address space): xxxx-xxxx xxxx-xxxx-xxxx-xxxx-xxxx-xxxx xxxx-xxxx AAAA-AAAA 1: Local address for WIP bit is found in Byte 1 of 48-bit command-address: (Byte 0 of 48-bit command-address space): xxxx-xxxx xxxx-xxxx-xxxx-xxxx-xxxx-xxxx AAAA-AAAA xxxx-xxxx
28	Sharing 0: Not shared: The device has separate bits for Program Error and Erase Error 1: Shared: The same bit is used for both Program Error and Erase Error
27:24	Bit location of Erase Error bit in register
23:16	Address of register where Erase Error is located
15:0	Reserved. Leave as “0”. (This allows new features to be added to these bits in the future.)

6.11.8 SCCR Map for xSPI Profile 2.0 Memory Devices Parameter Table: 6th DWORD – Variable Dummy Cycle Settings – Volatile Register

Bits	Description
31	Variable number of dummy cycles supported: 0: Not supported, or supported in a way that cannot be described correctly by this parameter table 1: Supported
30	Reserved. Leave as “0”. (This allows new features to be added to these bits in the future.)
29	0: Local address for Variable Dummy Cycle Setting bit is found in last byte of the command-address: (Byte 0 of 48-bit command-address space): xxxx-xxxx xxxx-xxxx-xxxx-xxxx-xxxx-xxxx xxxx-xxxx AAAA-AAAA 1: Local address for Variable Dummy Cycle Setting bit is found in Byte 1 of 48-bit command-address: (Byte 0 of 48-bit command-address space): xxxx-xxxx xxxx-xxxx-xxxx-xxxx-xxxx-xxxx AAAA-AAAA xxxx-xxxx
28:27	Number of physical bits used to set wait states 00: 2 bit 01: 3 bits 10: 4 bit 11: 5 bits
26:23	Bit location of LSb of physical bits in register
22:15	Address of register where Erase Error is located
14:0	Reserved. Leave as “0”. (This allows new features to be added to these bits in the future.)

6.11.9 SCCR Map for xSPI Profile 2.0 Memory Devices Parameter Table: 7th DWORD – Variable Dummy Cycle Settings- Non Volatile Register

Bits	Description
31	Variable number of dummy cycles supported: 0: Not supported, or supported in a way that cannot be described correctly by this parameter table 1: Supported
30	Reserved. Leave as “0”. (This allows new features to be added to these bits in the future.)
29	0: Local address for Variable Dummy Cycle Setting bit is found in last byte of the command-address: (Byte 0 of 48-bit command-address space): xxxx-xxxx xxxx-xxxx-xxxx-xxxx-xxxx-xxxx xxxx-xxxx AAAA-AAAA 1: Local address for Variable Dummy Cycle Setting bit is found in Byte 1 of 48-bit command-address: (Byte 0 of 48-bit command-address space): xxxx-xxxx xxxx-xxxx-xxxx-xxxx-xxxx-xxxx AAAA-AAAA xxxx-xxxx
28:27	Number of physical bits used to set wait states 00: 2 bit 01: 3 bits 10: 4 bit 11: 5 bits
26:23	Bit location of LSb of physical bits in register
22:15	Address of register where Erase Error is located
14:0	Reserved. Leave as “0”. (This allows new features to be added to these bits in the future.)

6.11.10 SCCR Map for xSPI Profile 2.0 Memory Devices Parameter Table: 8th DWORD – Variable Dummy Cycle Settings – bit patterns

Bits	Description
31	30 dummy cycles supported: 0: Not supported 1: Supported
30-26	Bit pattern used to set 30 dummy cycles: If less than 5 physical bits are used to set dummy cycles, the least significant bits are used, and the most significant bit(s) are set to 0.
25	28 dummy cycles supported: 0: Not supported 1: Supported
24-20	Bit pattern used to set 28 dummy cycles: If less than 5 physical bits are used to set dummy cycles, the least significant bits are used, and the most significant bit(s) are set to 0.
19	26 dummy cycles supported: 0: Not supported 1: Supported
18-14	Bit pattern used to set 26 dummy cycles: If less than 5 physical bits are used to set dummy cycles, the least significant bits are used, and the most significant bit(s) are set to 0.
13	24 dummy cycles supported: 0: Not supported 1: Supported
12-8	Bit pattern used to set 24 dummy cycles: If less than 5 physical bits are used to set dummy cycles, the least significant bits are used, and the most significant bit(s) are set to 0.
7	22 dummy cycles supported: 0: Not supported 1: Supported
6-2	Bit pattern used to set 22 dummy cycles: If less than 5 physical bits are used to set dummy cycles, the least significant bits are used, and the most significant bit(s) are set to 0.
1-0	Reserved. Leave as “0”. (This allows new features to be added to these bits in the future.)

6.11.11 SCCR Map for xSPI Profile 2.0 Memory Devices Parameter Table: 9th DWORD – Variable Dummy Cycle Settings – bit patterns

Bits	Description
31	20 dummy cycles supported: 0: Not supported 1: Supported
30-26	Bit pattern used to set 20 dummy cycles: If less than 5 physical bits are used to set dummy cycles, the least significant bits are used, and the most significant bit(s) are set to 0.
25	18 dummy cycles supported: 0: Not supported 1: Supported
24-20	Bit pattern used to set 18 dummy cycles: If less than 5 physical bits are used to set dummy cycles, the least significant bits are used, and the most significant bit(s) are set to 0.
19	16 dummy cycles supported: 0: Not supported 1: Supported
18-14	Bit pattern used to set 16 dummy cycles: If less than 5 physical bits are used to set dummy cycles, the least significant bits are used, and the most significant bit(s) are set to 0.
13	14 dummy cycles supported: 0: Not supported 1: Supported
12-8	Bit pattern used to set 14 dummy cycles: If less than 5 physical bits are used to set dummy cycles, the least significant bits are used, and the most significant bit(s) are set to 0.
7	12 dummy cycles supported: 0: Not supported 1: Supported
6-2	Bit pattern used to set 12 dummy cycles: If less than 5 physical bits are used to set dummy cycles, the least significant bits are used, and the most significant bit(s) are set to 0.
1-0	Reserved. Leave as “0”. (This allows new features to be added to these bits in the future.)

**6.11.12 SCCR Map for xSPI Profile 2.0 Memory Devices Parameter Table: 10th DWORD –
Variable Dummy Cycle Settings – bit patterns**

Bits	Description
31	10 dummy cycles supported: 0: Not supported 1: Supported
30-26	Bit pattern used to set 10 dummy cycles: If less than 5 physical bits are used to set dummy cycles, the least significant bits are used, and the most significant bit(s) are set to 0.
25	8 dummy cycles supported: 0: Not supported 1: Supported
24-20	Bit pattern used to set 8 dummy cycles: If less than 5 physical bits are used to set dummy cycles, the least significant bits are used, and the most significant bit(s) are set to 0.
19	6 dummy cycles supported: 0: Not supported 1: Supported
18-14	Bit pattern used to set 6 dummy cycles: If less than 5 physical bits are used to set dummy cycles, the least significant bits are used, and the most significant bit(s) are set to 0.
13	4 dummy cycles supported: 0: Not supported 1: Supported
12-8	Bit pattern used to set 4 dummy cycles: If less than 5 physical bits are used to set dummy cycles, the least significant bits are used, and the most significant bit(s) are set to 0.
7	2 dummy cycles supported: 0: Not supported 1: Supported
6-2	Bit pattern used to set 2 dummy cycles: If less than 5 physical bits are used to set dummy cycles, the least significant bits are used, and the most significant bit(s) are set to 0.
1-0	Reserved. Leave as “0”. (This allows new features to be added to these bits in the future.)

6.11.13 SCCR Map for xSPI Profile 2.0 Memory Devices Parameter Table: 11th DWORD – Output Driver Strength - Volatile

See JEDEC Standard JESD251, *eXpanded Serial Peripheral Interface (xSPI) for Non Volatile Memory Devices*, for details about Output Driver Strength values.

Bits	Description
31:30	Number of physical bits used to set Output Driver Strength 00: Control bits for Variable Output Driver Strength not available (or not available in a form that can be described in this format). 01: 1 bit 10: 2 bits 11: 3 bits
29	0: Local address for Output Driver Strength Setting bit is found in last byte of the command-address: (Byte 0 of 48-bit command-address space): xxxx-xxxx xxxx-xxxx-xxxx-xxxx-xxxx-xxxx xxxx-xxxx AAAA-AAAA 1: Local address for Variable Dummy Cycle Setting bit is found in Byte 1 of 48-bit command-address: (Byte 0 of 48-bit command-address space): xxxx-xxxx xxxx-xxxx-xxxx-xxxx-xxxx-xxxx AAAA-AAAA xxxx-xxxx
28:25	Bit location of MSb of physical bits in register
24:17	Address of register where Erase Error is located
16:0	Reserved. Leave as “0”. (This allows new features to be added to these bits in the future.)

6.11.14 SCCR Map for xSPI Profile 2.0 Memory Devices Parameter Table: 12th DWORD – Output Driver Strength – Non Volatile

See JEDEC Standard JESD251, *eXpanded Serial Peripheral Interface (xSPI) for Non-Volatile Memory Devices*, for details about Output Driver Strength values.

Bits	Description
31:30	Number of physical bits used to set Output Driver Strength 00: Control bits for Variable Output Driver Strength not available (or not available in a form that can be described in this format). 01: 1 bit 10: 2 bits 11: 3 bits
29	0: Local address for Output Driver Strength Setting bit is found in last byte of the command-address: (Byte 0 of 48-bit command-address space): xxxx-xxxx xxxx-xxxx-xxxx-xxxx-xxxx-xxxx xxxx-xxxx AAAA-AAAA 1: Local address for Variable Dummy Cycle Setting bit is found in Byte 1 of 48-bit command-address: (Byte 0 of 48-bit command-address space): xxxx-xxxx xxxx-xxxx-xxxx-xxxx-xxxx-xxxx AAAA-AAAA xxxx-xxxx
28:25	Bit location of MSb of physical bits in register
24:17	Address of register where Erase Error is located
16:0	Reserved. Leave as “0”. (This allows new features to be added to these bits in the future.)

6.11.15 SCCR Map for xSPI Profile 2.0 Memory Devices Parameter Table: 13th DWORD – Output Driver Strength control bit patterns

Bits	Description
31-29	Bit pattern to support Driver type 0 If less than 3 control bits are used to control Variable Output Driver Strength, the most significant bit(s) are unused and should be set to 0.
28-26	Bit pattern to support Driver type 1 If less than 3 control bits are used to control Variable Output Driver Strength, the most significant bit(s) are unused and should be set to 0.
25-23	Bit pattern to support Driver type 2 If less than 3 control bits are used to control Variable Output Driver Strength, the most significant bit(s) are unused and should be set to 0.
22-20	Bit pattern to support Driver type 3 If less than 3 control bits are used to control Variable Output Driver Strength, the most significant bit(s) are unused and should be set to 0.
19-17	Bit pattern to support Driver type 4 If less than 3 control bits are used to control Variable Output Driver Strength, the most significant bit(s) are unused and should be set to 0.
16-0	Reserved. Leave as “0”. (This allows new features to be added to these bits in the future.)

6.12 Status, Control and Configuration Register Map Offsets for Multi-Chip SPI Memory Devices

For multi-chip devices, each chip (die) will follow the same Status, Control and Configuration Register Map as described in 6.10. Direct commands are not an option in this case, register bits may only be accessed by a command specifying an address and a register value.

The local address for each bit remains the same for every die in the multi-chip device, but the address offset for each die will be different. The offset for die 0 is provided in 6.10, the offset for every additional die is provided in this section.

The length of the table indicates the number of dice in the multi-chip device. The example below indicates 4 dice, but any number from 2 and up may be used.

6.12.1 Status, Control and Configuration Register Map Parameter Header: 1st DWORD

Bits	Description
31:24	Parameter Table Length This field specifies how many DWORDs are in the Parameter table. NOTE This field is 1's based. Therefore, 1 indicates 1 DWORD.
23:16	Parameter Table Major Revision Number This 8-bit field indicates the major revision number of the parameter table. The value in this field is 01h for this table defined by JESD216E revision (unchanged from JESD216D revision). NOTE The Major Revision of JEDEC defined parameter tables can only be modified by updates to this standard.
15:8	Parameter Table Minor Revision Number This 8-bit field indicates the minor revision number of the Status, Control and Configuration Register Map Parameter Table. The value in this field is 01h for this table defined by JESD216D revision. NOTE The Minor Revision of the JEDEC owned parameter tables can only be modified by updates to this standard.
7:0	Parameter ID LSB The Status, Control and Configuration Register Map Offsets for Multi-Chip SPI Memory Devices is assigned the ID LSB of 88h.

6.12.2 Status, Control and Configuration Register Map Parameter Header: 2nd DWORD

Bits	Description
31:24	Parameter ID MSB The Status, Control and Configuration Register Map is assigned the ID MSB of FFh.
23:0	Parameter Table Pointer (PTP) This address specifies the start of this header's Parameter Table in the SFDP structure. The address is in terms of bytes and must be DWORD-aligned.

6.12.3 Status, Control and Configuration Register Map Parameter Table: 1st DWORD – Volatile registers address offset for die 1

Bits	Description
31:0	Address offset for volatile registers

6.12.4 Status, Control and Configuration Register Map Parameter Table: 2nd DWORD – Non-Volatile registers address offset for die 1

Bits	Description
31:0	Address offset for non-volatile registers

6.12.5 Status, Control and Configuration Register Map Parameter Table: 3rd DWORD – Volatile registers address offset for die 2

Bits	Description
31:0	Address offset for volatile registers

6.12.6 Status, Control and Configuration Register Map Parameter Table: 4th DWORD – Non-Volatile registers address offset for die 2

Bits	Description
31:0	Address offset for non-volatile registers

6.12.7 Status, Control and Configuration Register Map Parameter Table: 5th DWORD – Volatile registers address offset for die 3

Bits	Description
31:0	Address offset for volatile registers

6.12.8 Status, Control and Configuration Register Map Parameter Table: 6th DWORD – Non-Volatile registers address offset for die 3

Bits	Description
31:0	Address offset for non-volatile registers

6.13 Command Sequences to Change to Octal DDR (8D-8D-8D) mode

To simplify hardware based host controllers, a set of simple command sequences is provided which can be executed directly by the host controller to enable

- Octal DDR read mode
- 50 ohm I/O driver strength (Driver Type 0, mandatory for xSPI devices)
- 20 dummy cycles for Read Fast commands
- Operation at 100MHz (or higher, if supported)

This will typically be used when the host controller and target memory device are communicating in single SPI mode after power up, and the host controller is reading SFDP in this mode.

NOTE Using this command sequence will also change the Read SFDP behavior of the device. It is therefore recommended that the host reads all SFDP data from the device before changing modes.

For xSPI devices that do not boot in single SPI mode, this command sequence may not be applicable or required. If the device boots in Octal DDR mode with the above parameters set as default, no change is required. If the device settings after boot are different than described above, these sequences may be implemented to give the host controller an option to change to this operation mode. The host controller will have to determine the boot mode in this case as described in 4.5.

The host will have to send several command sequences of varying length to the xSPI device.

Each command sequence starts with CS pulled low, followed by one or more bytes of data clocked in on the SI/IO0 line (or multiple IO lines for other modes than single SPI mode) and finally CS is pulled high at the end. Each command sequence consists of 2 DWORDs (8 bytes) in the JEDEC xSPI (Profile 1.0) Parameter Table. The first byte of each command sequence indicates the length of the sequence (0 to 7 bytes), the following 7 indicates the byte values to be output by the host controller. A length of 0 indicates that the sequence is not required. For a length less than 7, the remaining values in the tables can be ignored. (They will typically be set to 0 by the device manufacturer, but may contain any value.) Up to 4 command sequences are supported. Command Sequence 1 and 3 (if required) will typically contain the Write Enable commands required for Command sequence 2 and 4.

It is important that the host controller outputs exactly the correct number of clock cycles as indicated by the length of each command sequence (8 per byte for single SPI mode), as the target device may ignore a command sequence that does not contain the correct number of clock cycles.

6.13.1 Command Sequences to Change to Octal DDR (8D-8D-8D) mode, Parameter Header: 1st DWORD

Bits	Description
31:24	<p>Parameter Table Length This field specifies how many DWORDs are in the Parameter table.</p> <p>NOTE This field is 1's based. Therefore, 1 indicates 1 DWORD.</p> <p>The Parameter Table length indicates how much of the Parameter Table is included in a device. If the parameters at the end of the Parameter Table are not applicable for a device, these entries may be omitted to save space.</p>
23:16	<p>Parameter Table Major Revision Number This 8-bit field indicates the major revision number of the parameter table. The value in this field is 01h for this table defined by JESD216E revision (unchanged from JESD216D revision).</p> <p>NOTE The Major Revision of JEDEC defined parameter tables can only be modified by updates to this standard.</p>
15:8	<p>Parameter Table Minor Revision Number This 8-bit field indicates the minor revision number of the parameter table. The value in this field is 00h for this table defined by JESD216E revision (unchanged from JESD216D revision).</p> <p>NOTE The Minor Revision of the JEDEC owned parameter tables can only be modified by updates to this standard.</p>
7:0	<p>Parameter ID LSB The Command Sequences to Change to Octal DDR (8D-8D-8D) mode is assigned the ID LSB of 0Ah.</p>

6.13.2 Command Sequences to Change to Octal DDR (8D-8D-8D) mode, Parameter Header: 2nd DWORD

Bits	Description
31:24	<p>Parameter ID MSB The Command Sequences to Change to Octal DDR (8D-8D-8D) is assigned the ID MSB of FFh.</p>
23:0	<p>Parameter Table Pointer (PTP) This address specifies the start of this header's Parameter Table in the SFDP structure. The address is in terms of bytes and must be DWORD-aligned.</p>

6.13.3 Command Sequences to Change to Octal DDR (8D-8D-8D) mode, Parameter Table: 1st DWORD - First Command Sequence

Bits	Description
31-24	Length of first command sequence (0 if not implemented)
23:16	Byte 1 of first command sequence
15:8	Byte 2 of first command sequence (if required)
7:0	Byte 3 of first command sequence (if required)

6.13.4 Command Sequences to Change to Octal DDR (8D-8D-8D) mode, Parameter Table: 2nd DWORD - First Command Sequence (continued)

Bits	Description
31-24	Byte 4 of first command sequence (if required)
23:16	Byte 5 of first command sequence (if required)
15:8	Byte 6 of first command sequence (if required)
7:0	Byte 7 of first command sequence (if required)

6.13.5 Command Sequences to Change to Octal DDR (8D-8D-8D) mode, Parameter Table: 3rd DWORD - 2nd Command Sequence

Bits	Description
31-24	Length of 2 nd command sequence (0 if not implemented)
23:16	Byte 1 of 2 nd command sequence
15:8	Byte 2 of 2 nd command sequence (if required)
7:0	Byte 3 of 2 nd command sequence (if required)

6.13.6 Command Sequences to Change to Octal DDR (8D-8D-8D) mode, Parameter Table: 4th DWORD - 2nd Command Sequence (continued)

Bits	Description
31-24	Byte 4 of 2 nd command sequence (if required)
23:16	Byte 5 of 2 nd command sequence (if required)
15:8	Byte 6 of 2 nd command sequence (if required)
7:0	Byte 7 of 2 nd command sequence (if required)

6.13.7 Command Sequences to Change to Octal DDR (8D-8D-8D) mode, Parameter Table: 5th DWORD - 3rd Command Sequence

Bits	Description
31-24	Length of 3 rd command sequence (0 if not implemented)
23:16	Byte 1 of 3 rd command sequence
15:8	Byte 2 of 3 rd command sequence (if required)
7:0	Byte 3 of 3 rd command sequence (if required)

6.13.8 Command Sequences to Change to Octal DDR (8D-8D-8D) mode, Parameter Table: 6th DWORD - 3rd Command Sequence (continued)

Bits	Description
31-24	Byte 4 of 3 rd command sequence (if required)
23:16	Byte 5 of 3 rd command sequence (if required)
15:8	Byte 6 of 3 rd command sequence (if required)
7:0	Byte 7 of 3 rd command sequence (if required)

**6.13.9 Command Sequences to Change to Octal DDR (8D-8D-8D) mode, Parameter Table: 7th
DWORD - 4th Command Sequence**

Bits	Description
31-24	Length of 4 th command sequence (0 if not implemented)
23:16	Byte 1 of 4 th command sequence
15:8	Byte 2 of 4 th command sequence (if required)
7:0	Byte 3 of 4 th command sequence (if required)

**6.13.10 Command Sequences to Change to Octal DDR (8D-8D-8D) mode, Parameter Table: 8th
DWORD - 4th Command Sequence (continued)**

Bits	Description
31-24	Byte 4 of 4 th command sequence (if required)
23:16	Byte 5 of 4 th command sequence (if required)
15:8	Byte 6 of 4 th command sequence (if required)
7:0	Byte 7 of 4 th command sequence (if required)

chengdu

6.14 x4 Quad IO with DS Parameter Header and Table

See JESD251-1, Addendum No. 1 to JESD251 – OPTIONAL x4 QUAD I/O WITH DATA STROBE for details about this interface.

6.14.1 x4 Quad IO with DS Parameter Header: 1st DWORD

Bits	Description
31:24	Parameter Table Length This field specifies how many DWORDs are in the Parameter table. NOTE This field is 1's based. Therefore, 1 indicates 1 DWORD.
23:16	Parameter Table Major Revision Number This 8-bit field indicates the major revision number of the parameter table. The value in this field is 01h for this table defined by JESD216D revision. NOTE The Major Revision of JEDEC defined parameter tables can only be modified by updates to this standard.
15:8	Parameter Table Minor Revision Number This 8-bit field indicates the minor revision number of the parameter table. The value in this field is 00h for this table defined by JESD216D revision. NOTE The Minor Revision of the JEDEC owned parameter tables can only be modified by updates to this standard.
7:0	Parameter ID LSB The eXpanded Serial Peripheral Interface is assigned the ID LSB of 0Ch.

6.14.2 x4 Quad IO with DS Parameter Header: 2nd DWORD

Bits	Description
31:24	Parameter ID MSB The eXpanded Serial Peripheral Interface is assigned the ID MSB of FFh.
23:0	Parameter Table Pointer (PTP) This address specifies the start of this header's Parameter Table in the SFDP structure. The address is in terms of bytes and must be DWORD-aligned.

6.14.3 x4 Quad IO with DS Parameter Table: 1st DWORD - Command Codes used in 4S-4D-4D protocol mode

The commands listed here are those that have more than one option for Command Code listed in “Table 2 Profile 1.0 commands used in 4S-4D-4D protocol mode (required commands)” or in “Table 3: Profile 1.0 commands used in 4S-4D-4D protocol mode (optional commands)” in the x4 Addendum to the xSPI standard JESD251 (JESD251-1).

The opcodes for the Erase commands are provided in 6.4.11 to 6.4.12 and are therefore not repeated here.

For the optional commands that are not supported as indicated in 3rd DWORD below, the parameter fields in this DWORD are not applicable.

Bits	Description
31	SFDP Command in 4S-4D-4D mode – Address Bytes See Figure 4 — Read SFDP (4S-4D-4D) Mode Timing Diagram 0b: 32-bit address (For most devices, SFDP is still limited to a 24-bit address space. This means MSB is 0, and the 24-bit address is in the last 3 bytes) 1b: 24-bit address, left adjusted (24-bit address is in the first 3 bytes, LSB is 0)
30	SFDP Command in 4S-4D-4D mode – Dummy Cycles See Figure 4 — Read SFDP (4S-4D-4D) Mode Timing Diagram 0b: 8 1b: 20
29	Number of Additional Modifier Bytes Used for Read Status Register command 1: 4 bytes 0: 0 bytes
28	Initial Latency (CK cycles) for Read Status Register command 1: 8 CK cycles 0: 4 CK cycles
27	Number of Additional Modifier Bytes Used for Read Register command 1: 4 bytes 0: 1 byte
26	Initial Latency (CK cycles) for Read Volatile Register command 1: 8 CK cycles 0: 4 CK cycles
25	Initial Latency (CK cycles) for Read Non-Volatile Register command 1: 8 CK cycles 0: 4 CK cycles
24	Number of Additional Modifier Bytes Used for Write Status-Cfg Register command 1: 4 bytes 0: 0 bytes
23	Number of Additional Modifier Bytes Used for Write Register command 1: 4 bytes 0: 1 byte
22	Number of Data Bytes Used for Write Register command 1: 2 bytes 0: 1 byte
21:16	Reserved. Leave as “0”. (This allows new features to be added to these bits in the future.)
15:8	Read Fast command
7:0	Read Fast Wrapped command 00h means not supported

6.14.4 x4 Quad IO with DS Parameter Table: 2nd DWORD - Command Codes used in 4S-4D-4D protocol mode

Bits	Description
31:24	Read Volatile Register command
23:16	Read NV Register command
15:8	Write Volatile Register command
7:0	Write NV Register command

6.14.5 x4 Quad IO with DS Parameter Table: 3rd DWORD - Memory Commands Supported in 4S-4D-4D protocol mode

This is the list of *optional* commands in 4S-4D-4D protocol mode. The command code for each of these is found in and Table 3 in the x4 xSPI Addendum to the xSPI standard JESD251 (JESD251-1). For the commands that have more than one option for Command Code listed in the xSPI standard, the command code for each of these is found in the JEDEC xSPI (Profile 1.0) Parameter Table: 1st to 2nd DWORD above. Table 6-2 in the xSPI standard lists the required commands for this profile. The required commands are not listed here.

6.14.6 x4 Quad IO with DS Parameter Table: 4th DWORD - Dummy cycles used for various frequencies

Bits	Description
31:12	Reserved. Leave as “0”. (This allows new features to be added to these bits in the future.)
11:7	200MHz operation: number of dummy cycles required A value of 0 means this frequency is not supported
6:2	200MHz operation: configuration bit pattern to set this number of dummy cycles
1:0	Reserved. Leave as “0”. (This allows new features to be added to these bits in the future.)

6.14.7 x4 Quad IO with DS Parameter Table: 5th DWORD - Dummy cycles used for various frequencies

Bits	Description
31:27	166MHz operation: number of dummy cycles required A value of 0 means this frequency is not supported
26:22	166MHz operation: configuration bit pattern to set this number of dummy cycles
21:17	133MHz operation: number of dummy cycles required A value of 0 means this frequency is not supported
16:12	133MHz operation: configuration bit pattern to set this number of dummy cycles
11:7	100MHz operation: number of dummy cycles required A value of 0 means this frequency is not supported
6:2	100MHz operation: configuration bit pattern to set this number of dummy cycles
1:0	Reserved. Leave as "0". (This allows new features to be added to these bits in the future.)

chengdu

6.15 Command Sequences to Change to Quad DDR (4S-4D-4D) mode

To simplify hardware based host controllers, a set of simple command sequences is provided which can be executed directly by the host controller to enable

- Quad DDR read mode
- 50 ohm I/O driver strength (Driver Type 0, mandatory for xSPI devices)
- 20 dummy cycles for Read Fast commands
- Operation at 100MHz (or higher, if supported)

This will typically be used when the host controller and target memory device are communicating in single SPI mode after power up, and the host controller is reading SFDP in this mode.

NOTE Using this command sequence will also change the Read SFDP behavior of the device. It is therefore recommended that the host reads all SFDP data from the device before changing modes.

For xSPI devices that do not boot in single SPI mode, this command sequence may not be applicable or required. If the device boots in Quad DDR mode with the above parameters set as default, no change is required. If the device settings after boot are different than described above, these sequences may be implemented to give the host controller an option to change to this operation mode. The host controller will have to determine the boot mode in this case as described in Section 4.5.

The host will have to send several command sequences of varying length to the xSPI device.

Each command sequence starts with CS pulled low, followed by one or more bytes of data clocked in on the SI/IO0 line (or multiple IO lines for other modes than single SPI mode) and finally CS is pulled high at the end. Each command sequence consists of 2 DWORDs (8 bytes) in the JEDEC xSPI (Profile 1.0) Parameter Table. The first byte of each command sequence indicates the length of the sequence (0 to 7 bytes), the following 7 indicates the byte values to be output by the host controller. A length of 0 indicates that the sequence is not required. For a length less than 7, the remaining values in the tables can be ignored. (They will typically be set to 0 by the device manufacturer, but may contain any value.) Up to 4 command sequences are supported. Command Sequence 1 and 3 (if required) will typically contain the Write Enable commands required for Command sequence 2 and 4.

It is important that the host controller outputs exactly the correct number of clock cycles as indicated by the length of each command sequence (8 per byte for single SPI mode), as the target device may ignore a command sequence that does not contain the correct number of clock cycles.

6.15.1 Command Sequences to Change to Quad DDR (4S-4D-4D) mode, Parameter Header: 1st DWORD

Bits	Description
31:24	<p>Parameter Table Length This field specifies how many DWORDs are in the Parameter table. NOTE This field is 1's based. Therefore, 1 indicates 1 DWORD.</p>
	<p>The Parameter Table length indicates how much of the Parameter Table is included in a device. If the parameters at the end of the Parameter Table are not applicable for a device, these entries may be omitted to save space.</p>
23:16	<p>Parameter Table Major Revision Number This 8-bit field indicates the major revision number of the parameter table. The value in this field is 01h for this table defined by JESD216D revision. NOTE The Major Revision of JEDEC defined parameter tables can only be modified by updates to this standard.</p>
15:8	<p>Parameter Table Minor Revision Number This 8-bit field indicates the minor revision number of the parameter table. The value in this field is 00h for this table defined by JESD216D revision. NOTE The Minor Revision of the JEDEC owned parameter tables can only be modified by updates to this standard.</p>
7:0	<p>Parameter ID LSB The Command Sequences to Change to Quad DDR (4S-4D-4D) mode is assigned the ID LSB of 8Dh.</p>

6.15.2 Command Sequences to Change to Quad DDR (4S-4D-4D) mode, Parameter Header: 2nd DWORD

Bits	Description
31:24	<p>Parameter ID MSB The Command Sequences to Change to Quad DDR (4S-4D-4D) is assigned the ID MSB of FFh.</p>
23:0	<p>Parameter Table Pointer (PTP) This address specifies the start of this header's Parameter Table in the SFDP structure. The address is in terms of bytes and must be DWORD-aligned.</p>

6.15.3 Command Sequences to Change to Quad DDR (4S-4D-4D) mode, Parameter Table: 1st DWORD - First Command Sequence

Bits	Description
31-24	Length of first command sequence (0 if not implemented)
23:16	Byte 1 of first command sequence
15:8	Byte 2 of first command sequence (if required)
7:0	Byte 3 of first command sequence (if required)

6.15.4 Command Sequences to Change to Quad DDR (4S-4D-4D) mode, Parameter Table: 2nd DWORD - First Command Sequence (continued)

Bits	Description
31-24	Byte 4 of first command sequence (if required)
23:16	Byte 5 of first command sequence (if required)
15:8	Byte 6 of first command sequence (if required)
7:0	Byte 7 of first command sequence (if required)

6.15.5 Command Sequences to Change to Quad DDR (4S-4D-4D) mode, Parameter Table: 3rd DWORD - 2nd Command Sequence

Bits	Description
31-24	Length of 2 nd command sequence (0 if not implemented)
23:16	Byte 1 of 2 nd command sequence
15:8	Byte 2 of 2 nd command sequence (if required)
7:0	Byte 3 of 2 nd command sequence (if required)

6.15.6 Command Sequences to Change to Quad DDR (4S-4D-4D) mode, Parameter Table: 4th DWORD - 2nd Command Sequence (continued)

Bits	Description
31-24	Byte 4 of 2 nd command sequence (if required)
23:16	Byte 5 of 2 nd command sequence (if required)
15:8	Byte 6 of 2 nd command sequence (if required)
7:0	Byte 7 of 2 nd command sequence (if required)

6.15.7 Command Sequences to Change to Quad DDR (4S-4D-4D) mode, Parameter Table: 5th DWORD - 3rd Command Sequence

Bits	Description
31-24	Length of 3 rd command sequence (0 if not implemented)
23:16	Byte 1 of 3 rd command sequence
15:8	Byte 2 of 3 rd command sequence (if required)
7:0	Byte 3 of 3 rd command sequence (if required)

6.15.8 Command Sequences to Change to Quad DDR (4S-4D-4D) mode, Parameter Table: 6th DWORD - 3rd Command Sequence (continued)

Bits	Description
31-24	Byte 4 of 3 rd command sequence (if required)
23:16	Byte 5 of 3 rd command sequence (if required)
15:8	Byte 6 of 3 rd command sequence (if required)
7:0	Byte 7 of 3 rd command sequence (if required)

6.15.9 Command Sequences to Change to Quad DDR (4S-4D-4D) mode, Parameter Table: 7th DWORD - 4th Command Sequence

Bits	Description
31-24	Length of 4 th command sequence (0 if not implemented)
23:16	Byte 1 of 4 th command sequence
15:8	Byte 2 of 4 th command sequence (if required)
7:0	Byte 3 of 4 th command sequence (if required)

6.15.10 Command Sequences to Change to Quad DDR (4S-4D-4D) mode, Parameter Table: 8th DWORD - 4th Command Sequence (continued)

Bits	Description
31-24	Byte 4 of 4 th command sequence (if required)
23:16	Byte 5 of 4 th command sequence (if required)
15:8	Byte 6 of 4 th command sequence (if required)
7:0	Byte 7 of 4 th command sequence (if required)

6.16 Secure Packet READ/WRITE Parameter Header and Table

As serial flash manufacturers have adopted cryptographic security in their devices the need for a packet transfer transaction has emerged. This SFDP specification (starting with JESD216E) describes critical characteristics that allow a host to successfully utilize the Secure Packet READ and Secure Packet WRITE transactions supported on an enabled device.

6.16.1 Secure Packet READ/WRITE Parameter Header: 1st DWORD

Bits	Description
31:24	Parameter Table Length = 04h This field specifies how many DWORDs are in the Parameter table. NOTE This field is 1's based. Therefore, 1 indicates 1 DWORD.
23:16	Parameter Table Major Revision Number = 01h This 8-bit field indicates the major revision number of the parameter table. The value in this field is 01h for this table is newly defined by JESD216E revision. NOTE The Major Revision of JEDEC defined parameter tables can only be modified by updates to this standard.
15:8	Parameter Table Minor Revision Number = 00h This 8-bit field indicates the minor revision number of the parameter table. The value in this field is 00h for this table is newly defined by JESD216E revision. NOTE The Minor Revision of the JEDEC owned parameter tables can only be modified by updates to this standard.
7:0	Parameter ID LSB = 8Eh The Secure Packet READ/WRITE Parameter Table is assigned the ID (LSB) of 8Eh.

6.16.2 Secure Packet READ/WRITE Parameter Header: 2nd DWORD

Bits	Description
31:24	Parameter ID MSB = FFh The Secure Packet READ/WRITE Parameter Table is assigned the ID (MSB) of FFh.
23:0	Parameter Table Pointer (PTP) = <i>manufacturer specified</i> This address specifies the start of this header's Parameter Table in the SFDP structure. The address is in terms of bytes and must be DWORD-aligned.

6.16.3 Secure Packet READ/WRITE Parameter Table, 1st DWORD

Bits	Description
31:30	Number of Latency Clocks for Secure READ (see JESD216 6.4-6.10) 00b: Same as Fast Read number of latency cycles 01b: Same as Linear/Wrapped Read number of latency clocks 10b: Reserved 11b: Reserved
29:28	Size of Command Modifier field 00b: 0 bytes 01b: 3 bytes 10b: 4 bytes 11b: 3 or 4 bytes (as described by Address Byte definition in JESD216 6.4.4)
27:24	Packet Buffer Size (largest packet size allowed) 0000b: 64 bytes 0001b: 128 bytes 0010b: 256 bytes 0011b: 512 bytes 0100b: 1024 bytes 0101b: 2048 bytes others: Reserved
23:8	Reserved
7:0	Secure Packet Structure = <i>manufacturer specified</i> xxxxxxx1b = Proprietary xxxxxxx1xb = SPDM xxxxx1xxb = RPMC others = Reserved

6.16.4 Secure Packet READ/WRITE Parameter Table, 2nd DWORD

Bits	Description (<i>00h means that the command opcode is not supported</i>)
31:24	x1 SDR Secure Packet READ Command Opcode = <i>manufacturer specified</i>
23:16	x1 SDR Secure Packet WRITE Command Opcode = <i>manufacturer specified</i>
15:8	x2 SDR Secure Packet READ Command Opcode = <i>manufacturer specified</i>
7:0	x2 SDR Secure Packet WRITE Command Opcode = <i>manufacturer specified</i>

6.16.5 Secure Packet READ/WRITE Parameter Table, 3rd DWORD

Bits	Description (<i>00h means that the command opcode is not supported</i>)
31:24	x4 SDR Secure Packet READ Command Opcode = <i>manufacturer specified</i>
23:16	x4 SDR Secure Packet WRITE Command Opcode = <i>manufacturer specified</i>
15:8	x8 SDR Secure Packet READ Command Opcode = <i>manufacturer specified</i>
7:0	x8 SDR Secure Packet WRITE Command Opcode = <i>manufacturer specified</i>

6.16.6 Secure Packet READ/WRITE Parameter Table, 4th DWORD

Bits	Description (<i>00h means that the command opcode is not supported</i>)
31:24	x4 DDR Secure Packet READ Command Opcode = <i>manufacturer specified</i>
23:16	x4 DDR Secure Packet WRITE Command Opcode = <i>manufacturer specified</i>
15:8	x8 DDR Secure Packet READ Command Opcode = <i>manufacturer specified</i>
7:0	x8 DDR Secure Packet WRITE Command Opcode = <i>manufacturer specified</i>

chengdu

7 Rules for Header and Table Additions and Modifications

- Additional headers and parameter tables can be added by vendors without JEDEC approval.
- The first four DWORDS of the 6.4 JEDEC Flash Parameters Table can never be modified.
- New headers must be built using exactly two DWORDS and they must immediately follow the existing header(s).
- Minimum parameter table size is one DWORD. The maximum parameter table size is not specified.
- Parameter tables may be located anywhere in the SFDP space. They do not need to immediately follow the parameter headers.
- Overlapping parameter tables are permitted.

chengdu

8 Legacy Compatibility

Prior to the release of this standard, Intel published SFDP guidelines with a four DWORD parameter table. The first four DWORDs of the JEDEC Basic Parameter Table are identical to the table in Intel's guidelines. Devices in production prior to the release of the initial JESD216 standard might only contain these four DWORDs.

Revision A increased the number of DWORDs from nine to sixteen. The first nine DWORDs in Revision A maintain backwards compatibility. Devices in production prior to the release of this revision may not contain all of the currently defined DWORDs.

Revision B continues to maintain backwards compatibility of the Basic Parameter Table. Optional Function Specific tables for Sector Map Parameters and 4-Byte address commands are added. See Annex B revision history for details.

Revision C continues to maintain backwards compatibility of the Basic Parameter Table, Optional Function Specific tables for Sector Map Parameters and 4-Byte address commands. Definitions for Octal interface devices are added. See Annex B revision history for details.

Revision D continues to maintain backwards compatibility of the Basic Parameter Table, Optional Function Specific tables for Sector Map Parameters, 4-Byte address commands, and Octal interface devices. Definitions for x4 (Quad) interface devices are added and dummy cycle definitions for some registers are changed. See Annex B revision history for details.

Revision E continues to maintain backwards compatibility of the Basic Parameter Table, Optional Function Specific tables for Sector Map Parameters, 4-Byte address commands, Octal interface devices, definitions for x4 (Quad) interface devices and dummy cycle definitions for some registers are changed. Definitions for RPMC and Secure Read/Write transactions have been added to Revision E. See Annex B revision history for details.

Annex A (Informative) Procedure For Requesting Function Specific ID

The Function Specific ID list is not a fixed listing. Any company may request a Function Specific ID by making a request to the JEDEC office at juliec@jedec.org. Please include “Function Specific ID Request, JESD216” in the email subject line. Upon receipt of the email the request will be forwarded to the JC-42.4 Chair and the JC-42.4 TG Chair for committee consideration. The chair will then respond to the request. Updates to the list will be made periodically.

The SFDP Standard will allow Serial Flash vendors to describe the functions and features of their devices in a standard set of internal parameter tables. These internal parameter tables can be read by users to determine the characteristics of the device.

chengdu

Annex B (informative) Differences between revisions

This annex briefly describes most of the changes made to entries that appear in this standard, JESD216E, compared to its predecessors, JESD216D.01 (August 2019, JESD216D (August 2019), JESD216C (August 2018), JESD216B (May 2014), JESD216A (July 2013) and JESD216 (April 2011).

B.1 Differences between JESD216E and JESD216D.01

Clause	Description of change
6.6	Added “Replay Protected Monotonic Counters (RPMC) Parameter Header and Table”
6.16	Added “Secure Packet READ/WRITE Parameter Header and Table”

Editorial changes made by Serial Flash TG on March 1, 2021

NOTE The page numbers shown below are from the original JESD216E document and do not necessarily match the page numbers in this revised document. Additionally, the page numbers are the spec page numbers shown at the top of each page and not the physical page numbers.

- 1) Globally changed:
 - a. “master” to “initiator” (19 instances)
 - b. “slave” to “target” (30 instances)
 - c. Made appropriate “JESD216D” to “JESD216E” changes
 - d. “eXtended” to “eXpanded” when describing xSPI acronym
 - e. Updated the normative reference list
 - f. Various typos
- 2) Removed references to “Sector Map” from the 1st DWORD of the following parameter headers:
 - a. Clause 6.7.1: 4-Bytes Address Instruction Parameter Header
 - b. Clause 6.8.1: JEDEC xSPI (Profile 1.0) Parameter Header
 - c. Clause 6.13.1: Command Sequences to Change Octal DDR (8D-8D-8D) mode, Parameter Header
 - d. Clause 6.14.1: x4 Quad IO with DS Parameter Header
 - e. Clause 6.15.1: Command Sequences to Change to Quad DDR (4S-4D-4D) mode, Parameter Header

B.2 Differences between JESD216D.01 and JESD216D

Editorial changes made by Serial Flash TG on August 1, 2019

NOTE The page numbers shown below are from the original JESD216D document and do not necessarily match the page numbers in this revised document. Additionally, the page numbers are the spec page numbers shown at the top of each page and not the physical page numbers.

- 1) Globally changed:
 - a. “supported” to “supported” (160 instances)
- 2) Page 3: Clause 3, “difinitions” corrected to “definitions”
- 3) Page 8: Clause 4.5.6, inserted missing timing diagram for Figure 6
- 4) Page 13: Clause 6.2.2,
 - a. bits[31:24], “See 0” corrected to “See 6.2.3”
 - b. bits[15:8], “1” corrected to “01h”
 - c. bits[7:0]. “8” corrected to “08h”
- 5) Page 15: Clause 6.2.3, F1h, “See Error! Reference source not found.” changed to “See Figure 12”
- 6) Page 17: Clause 6.2.3, add caption “Figure 11 — xSPI NAND Class-1 Device Read SFDP Flow”
- 7) Page 18: Clause 6.2.3, add caption “Figure 12 — xSPI NAND Class-2 Device Read SFDP Flow”
- 8) Page 19: Clause 6.3,
 - a. Added a comma after “If a vendor chooses to include multiple revisions of the Basic Parameter Table”
 - b. Corrected “see 0” to “see 6.2.2”
- 9) Page 21: Clause 6.3.3.1,
 - a. Changed “Reserved for next Function Specific Table assignment ID from FF0C to FF8E”

- b. Added “x4 Quad IO with DS” and assigned ID = “FF0C”
 - c. Added “Command Sequences to change to Quad DDR (4S-4D-4D) mode” with ID = “FF8D”
- 10) Page 24: Clause 6.4.1,
- a. bits[23:16], “1” corrected to “01h”
 - b. bits[15:8], “7” corrected to “07h”
- 11) Page 25: Clause 6.4.3, DWORD 18, “Jedec” corrected to “JEDEC”
- 12) Page 40: Clause 6.4.18, bits[22:20], 010b, removed double “..” after the word “zero”
- 13) Page 41: Clause 6.4.18, bits[3:0], x1xxb, removed double “..” after “800003h”
- 14) Page 43: Clause 6.4.19, bits[13:8], change “issued on 1, 2, or 4 wires” to “issued on 1, 2, 4, or 8 wires”
- 15) Page 45: Clause 6.4.21, bits[25:24], 01b,
- a. Inserted space between “01b:” and “Start”
 - b. Changed “in in” to “in”
 - c. Changed “1: JEDEC SPI Protocol Reset implemented as described in JEDEC SPI Protocol Reset spec” to “1: JEDEC SPI Protocol Reset implemented as described in JESD252”
- 16) Page 46: Clause 6.4.21, changed “198th DWORD” to “18th DWORD”
- 17) Page 47: Clause 6.4.21, changed “208th DWORD” to “18th DWORD”
- 18) Page 52: Clause 6.4.23, changed “210th DWORD” to “20th DWORD”
- 19) Page 54: Clause 6.5.1,
- a. bits[23:16], “1” corrected to “01h”
 - b. bits[15:8], “0” corrected to “00h”
- 20) Page 57: Clause 6.5.4, removed double “for for” in “A DWORD for for each...”
- 21) Page 64: Clause 6.6.1,
- a. bits[23:16], “1” corrected to “01h”
 - b. bits[15:8], “1” corrected to “01h”
- 22) Page 75: Clause 6.8.3, bit[21], “Enbale” corrected to “Enable”
- 23) Page 78: Clause 6.9.1,
- a. bits[23:16], “1” corrected to “01h”
 - b. bits[15:8], “1” corrected to “01h”
- 24) Page 103: Clause 6.9.27, bit[30], replaced 2 instances of “means means” with “means”
- 25) Page 108: Clause 6.10.1,
- a. bits[23:16], “1” corrected to “01h”
 - b. bits[15:8], “0” corrected to “00h”
- 26) Page 118: Clause 6.11.1,
- a. bits[23:16], “1” corrected to “01h”
 - b. bits[15:8], “1” corrected to “01h”
- 27) Page 121: Clause 6.12.1,
- a. bits[23:16], “1” corrected to “01h”
 - b. bits[15:8], “0” corrected to “00h”
- 28) Page 124:
- a. Clause 6.13, reworded “~~See JESD251, eXpanded Serial Peripheral Interface (xSPI) for Non-Volatile Memory Devices x4 xSPI Addendum (still at committee level for discussion)~~” to “See JESD251-1, Addendum No. 1 to JESD251 – OPTIONAL x4 QUAD I/O WITH DATA STROBE”
 - b. Clause 6.13.3, removed “(still at committee level for discussion)”
- 29) Page 125: Clause 6.13.3, bit[31], changed “24 bit” to “24-bit” for 2 instances
- 30) Page 126: Clause 6.13.5, replace “(still at committee level for discussion)” with “(JESD251-1)”
- 31) Page 129: Clause 6.14.1,
- a. Bits[23-16], “1” corrected to “01h”
 - b. Bits[15-8], “0” corrected to “00h”
 - c. Bits[7:0], “09h” corrected to “8Dh”

B.3 Differences between JESD216D and JESD216C

Clause	Description of change
6.3.3.1	Added ID FF0C for “x4 Quad IO with DS”; changed “Reserved for next Function Specific Table assignment” from FF0C to FF8D.

- 6.9.5 SCCR Map for SPI Memory Devices Parameter Table: 3rd DWORD, *Bits 27:26 Number of dummy bytes used for Generic Addressable Read Status/Control register command for volatile registers in (1S-1S-1S) mode* and 5:0 Reserved are redefined
- 6.9.6 SCCR Map for SPI Memory Devices Parameter Table: 4th DWORD, *Bits 27:26 Number of dummy bytes used for Generic Addressable Read Status/Control register command for volatile registers in (1S-1S-1S) mode* and 5:0 Reserved are redefined

Added the following new optional sections:

- 6.13 x4 Quad IO with DS Parameter Header and Table
- 6.14 Command Sequences to Change to Quad DDR (4S-4D-4D) mode

B.4 Differences between JESD216C and JESD216B

Clause	Description of change
3	Terms and definitions: Updated description of command mode nomenclature
6.2.2	SFDP Header: 2nd DWORD: Bits 31:24 redefined as SFDP Access Protocol. Updated definition of bits 23:16, Number of Parameter Headers (NPH).
Added 6.2.3	Definition of SFDP Access Protocol Field
6.4.20 – 6.2.23	Added DWORDs 17 to 20 to the JEDEC Basic Flash Parameter Header and Table.

Added the following new optional sections:

- 6.7 JEDEC eXpanded Serial Peripheral Interface (xSPI) Profile 1.0 Parameter Header and Table
- 6.8 JEDEC eXpanded Serial Peripheral Interface (xSPI) Profile 2.0 Parameter Header and Table
- 6.9 Status, Control and Configuration Register Map for SPI Memory Devices
- 6.10 Status, Control and Configuration Register Map Offsets for Multi-Chip SPI Memory Devices
- 6.11 Command Sequences to Change to Octal DDR (8D-8D-8D) mode

Removed the example code in the previous Annex A and Annex B, and renamed Annex C and Annex D accordingly

B.4.1 Editorial changes made by Serial Flash TG on August 17, 2018

- 1) Globally changed:
 - a. “Bit is set /cleared by” to “Bit is accessed by” (16 instances)
 - b. “Bit is set/cleared by” to “Bit is accessed by” (32 instances)
 - c. “Bits are set /cleared by” to “Bits are accessed by” (4 instances)
 - d. “Bits are set/cleared by” to “Bits are accessed by” (8 instances)
- 2) Page 7: “See 0...” – Changed to a link to section 6.4.21 “See 6.4.21...”
- 3) Page 12: To use a format consistent with the rest of the document, “DWORD 2” changed to “the 2nd DWORD” and “DWORD 15” changed to “the 15th DWORD”.
- 4) Page 14: Clause 6.2.3,
 - a. Removed flow diagram from SFDP Command Parameter Value 240/F0h (Decimal/Hex) and created new “Figure 11 — xSPI NAND Class-1 Device Read SFDP Flow”
 - b. Added “(see Figure 11)” reference: “Follow Long latency NVM Class-1 device SFDP access behavior for reading SFDP & MSPT data (see Figure 11):” to SFDP Command Parameter Value 240/F0h (Decimal/Hex) and 244/F4h (Decimal/Hex)
- 5) Page 15: Clause 6.2.3,
 - a. Removed flow diagram from SFDP Command Parameter Value 241/F1h (Decimal/Hex) and created new “Figure 12 — xSPI NAND Class-2 Device Read SFDP Flow”
 - b. Added “(see Figure 12)” reference: “Follow Long latency NVM Class-2 device SFDP access behavior for reading SFDP & MSPT (see Figure 12):”
- 6) Page 17: Clause 6.3.3, Changed the reference “see Annex C” to “see Annex A”
- 7) Page 19: To use a format consistent with the rest of the document, “DWORD 3” changed to “the 3rd DWORD” (two instances on the page).
- 8) Page 23: Clause 6.4.4, bits 18:17: After “All SFDP accesses use 3-byte addressing.” we should add “A device using 4-byte only addressing may still support 03h read using 3-byte addressing.”

B.4.1 Editorial changes made by Serial Flash TG on August 17, 2018 (cont'd)

- 9) Page 28: Clause 6.4.11. To use a format consistent with the rest of the document,
 - a. “DWORDS 8 or 9” changed to “the 8th or 9th DWORD”
 - b. “DWORD 10” changed to “the 10th DWORD”
- 10) Page 45: Clause 6.4.22
 - a. bits 8:4 “x_xx1xb: Issue instruction E8h” should read “x_xx1xb: Issue instruction 06h (WREN), then issue instruction E8h”
 - b. bits 3:0 add a line between the two already there: “xx1xb: Issue instruction 06h (WREN), then issue FFh instruction”
- 11) Page 63: Clause 6.7.1, bits 7:0 “The eXpanded Serial Peripheral Interface is assigned the ID LSB of 05h.” changed to “The eXpanded Serial Peripheral Interface (Profile 1) is assigned the ID LSB of 05h.”
- 12) Page 68: Clause 6.9.1, bits 7:0
 - a. “Parameter ID LSB (0x86)” changed to “Parameter ID LSB (0x06)”
 - b. “Refer to Definition of Parameter ID Field in below.” Changed to “The eXpanded Serial Peripheral Interface (Profile 2) is assigned the ID LSB of 06h.”
- 13) Page 71: “xSPI Profile 2.0 Octal memory devices are covered in 6.9.10.” This link should be “6.11”
- 14) Page 72: “Which of the two options is used is described in 6.9.5.” Actually, this is not only found in 6.10.5, it is described for every bit. So we should write “Which of the two options is used is described in the parameter table for each bit.”
- 15) Page 72: Clause 6.10.1, bits 7:0 “The Status, Control and Configuration Register Map is assigned the ID LSB of 06h.” changed to “... ID LSB of 87h”
- 16) Page 80: Clause 6.10.11
 - a. Bit 30-29: “2 bit” and “4 bit” changed to “2 bits” and “4 bits”
 - b. Bit 26-24: Added comment: “(Requirements: The physical bits used in a device are in the same (one) register, the bits form a continuous field and the bits are in order. If these requirements are not met, bit 31 above has to be set to 0.)”
- 17) Page 91: Clause 6.10.22, This is a volatile bit, all references to non-volatile bits are typos (copied from previous table by mistake). This typo is found in bits 31, 30, 27 (twice) and 26-24. “Non-Volatile” changed to “Volatile”
- 18) Page 101: Clause 6.11.1, bits 7:0 “The Status, Control and Configuration Register Map is assigned the ID LSB of 06h.” changed to “The Status, Control and Configuration Register Map for xSPI Profile 2.0 is assigned the ID LSB of 09h”
- 19) Page 109: Clause 6.11.14 “See the JEDEC xSPI Standard for details about Output Driver Strength values.” should be updated to “See the JEDEC Standard JESD251, *eXpanded Serial Peripheral Interface (xSPI) for Non-Volatile Memory Devices*, for details about Output Driver Strength values.”
- 20) Page 111: Clause 6.12.1, bits 7:0 “The Status, Control and Configuration Register Map is assigned the ID LSB of 88h.” changed to “The Status, Control and Configuration Register Map Offsets for Multi-Chip SPI Memory Devices is assigned the ID LSB of 88h.”
- 21) Page 114: Clause 6.13.1 bits 7:0 “The Command Sequences to Change to Octal DDR (8D-8D-8D) mode is assigned the ID LSB of 09h.” should be “... ID LSB of 0Ah.”

B.4.1 Editorial changes made by Serial Flash TG on August 17, 2018 (cont'd)

- 22) Page 117: Section 8, Changed references in the text containing “See Annex D’ to “See Annex B”
- 23) Updated Contents page numbers
- 24) Inserted Figures 11 & 12 in the figures listed in the Contents and updated the figure and page numbers
- 25) Updated the figure references in the text to match the new figure numbers:
 - a. Figure 11 -> Figure 13 (2 instances on old page 19; new page 22)
 - b. Figure 12 -> Figure 14 (1 instance on old page 19; new page 22)
 - c. Figure 13 -> Figure 15 (2 instances on old page 19; new page 22)
 - d. Figure 14 -> Figure 16 (2 instances on old page 19; new page 22)
 - e. Figure 16 -> Figure 18 (1 instance on old page 42; new page 45)
 - f. Figure 17 -> Figure 19 (1 instance on old page 42; new page 45)
 - g. Figure 18 -> Figure 20 (1 instance on old page 42; new page 45)

B.5 Differences between JESD216B and JESD216A

- Added a definition for Sector and Block to clarify terminology
- Changed Sector Type nomenclature to Erase Type, to clarify that the erase operation type is independent of the minimum erase granularity of the sectors affected by the erase operation e.g., several erase types (sizes of erase operations e.g., 8KB, 32KB, 64KB) may be applied to sectors of a smaller granularity than the erase operation (e.g., 4KB sectors).
- Clarified parameter ID LSB parity being located in the most significant Bit of the Byte
- Added the Function Specific Parameter Table ID assignments
- Added the Header for the JEDEC Basic Flash Parameter Table, separate from the general description for Parameter Table Headers. Removed references to the Basic Flash Parameter Table in the general Parameter Table Header description. Incremented the JEDEC Basic Flash Parameter Table Minor Revision to 6 as an indication that there has been an additional definition for a previously reserved bits: DWORD 15[18, 14, & 8].
- Removed use of the terms “sector” or “block” in relationship to erase operations, instead using the term Erase Type
- DW11, [31:24] Clarified the Chip Erase time applies separately to each die for multi-die devices in which the dice are individually accessed.
- DW12, [23:20], [12:9], Added comments that suspend can be issued at any time, there is no required minimum timing. However, ... this parameter recommends an average resume to suspend interval so the operation can make progress
- DW15, [23], Updated description and replaced WP by RESET
- DW15, [8:4], added 4-4-4 enable option
- Added a section with the optional Function Specific Sector Map Parameter Tables
- Added a section with the optional Function Specific 4-Byte Address Instruction Tables
- Added Annex B code example for Sector Map Parameter Table reading and moved previous Annex B and Annex C to be Annex C and Annex D

B.6 Differences between JESD216A and JESD216

- Extensive rewrite to clarify requirements, but functionality of JESD216 has been maintained.
- The JESD216A parameter table is marked with Major Revision 1 and Minor Revision 5. Using Minor Revision 5 instead of 1 is required to avoid version conflicts with legacy devices which implemented SFDP tables prior to JEDEC standardization.
- Increased the number of DWORDS in the Basic Parameters Table from nine to sixteen.
- Provided hooks for future expansion using Function Specific Tables.
- Added Annex A Example code for SFDP discovery
- Added Annex B Procedure for requesting a Function Specific ID



Standard Improvement Form**JEDEC****JESD216E**

The purpose of this form is to provide the Technical Committees of JEDEC with input from the industry regarding usage of the subject standard. Individuals or companies are invited to submit comments to JEDEC. All comments will be collected and dispersed to the appropriate committee(s).

If you can provide input, please complete this form and return to:

JEDEC
Attn: Publications Department
3103 North 10th Street
Suite 240 South
Arlington, VA 22201-2107

Fax: 703.907.7583

1. I recommend changes to the following:

Requirement, clause number _____

Test method number _____ Clause number _____

The referenced clause number has proven to be:

Unclear Too Rigid In Error

Other _____

2. Recommendations for correction:

3. Other suggestions for document improvement:

Submitted by

Name: _____

Phone: _____

Company: _____

E-mail: _____

Address: _____

City/State/Zip: _____

Date: _____

JEDEC[®]

The JEDEC logo consists of the word "JEDEC" in a bold, italicized, sans-serif font. A red horizontal line is positioned below the text, starting under the 'J' and extending to the right, ending under the 'C'. A registered trademark symbol (®) is located to the right of the 'C'.

chengdu